

AA2010-1

**AIRCRAFT ACCIDENT
INVESTIGATION REPORT**

SHIN NIHON HELICOPTER CO., LTD.

J A 6 0 5 5

Jan 29, 2010

Japan Transport Safety Board

The investigation for this report was conducted by Japan Transport Safety Board, JTSB, about the aircraft accident of Shin Nihon Helicopter Co., Ltd., Bell206L-3 registration JA6055 in accordance with the Act for the Establishment of the Japan Transport Safety Board and Annex 13 to the Convention on International Civil Aviation for the purpose of determining causes of the aircraft accident and contributing to the prevention of accidents/incidents and not for the purpose of blaming responsibility of the accident.

This English version of this report has been published and translated by JTSB to make its reading easier for English speaking people who are not familiar with Japanese. Although efforts are made to translate as accurately as possible, only the Japanese version is authentic. If there is any difference in the meaning of the texts between the Japanese and English versions, the text in the Japanese version prevails.

Norihiro Goto,
Chairman,
Japan Transport Safety Board

AIRCRAFT ACCIDENT INVESTIGATION REPORT

SHIN NIHON HELICOPTER CO., LTD.
BELL 206L-3 (ROTORCRAFT), JA6055
MINAKAMI-MACHI, TONE-GUN, GUNMA PREFECTURE,
AROUND 9:53 JST, FEBRUARY 10, 2009

December 18, 2009

Adopted by the Japan Transport Safety Board (Aircraft Sub-committee)

Chairman	Norihiro Goto
Member	Yukio Kusuki
Member	Shinsuke Endo
Member	Noboru Toyooka
Member	Yuki Shuto
Member	Akiko Matsuo

1. PROCESS AND PROGRESS OF THE AIRCRAFT ACCIDENT INVESTIGATION

1.1 Summary of the Accident

On February 10 (Tuesday), 2009, a Bell 206L-3, registered JA6055, operated by Shin Nihon Helicopter Co. Ltd., took off from a temporary helipad in Numata City, Gunma Prefecture around 09:38 for transmission line inspection, and contacted one of transmission lines that intersects the subject transmission line and crashed into a nearby field around 09:53 Japan Standard Time (JST, UTC+9H)¹.

On board the aircraft were a pilot in command and a transmission line inspector. Both sustained serious injuries.

The aircraft sustained substantial damage, but no fire broke out.

1.2 Outline of the Accident Investigation

1.2.1 Investigation Organization

Japan Transport Safety Board designated an investigator-in-charge and an investigator for the accident on February 10, 2009.

1.2.2 Representatives from Foreign Authorities

An accredited representative from the United States, the State of Design and Manufacture, participated in the investigation.

1.2.3 Implementation of the Investigation

February 10-11, 2009	On-site investigation and interview
February 20, 2009	Detailed examination of the Aircraft and pertaining documents
March 6 and April 9, 2009	Interview

1.2.4 Comments from the Parties Relevant to the Cause of the Accident

Comments were submitted from the parties relevant to the cause of the accident.

1.2.5 Comments from the Participating State

Comments were invited from the participating state.

¹ Unless otherwise stated, all times are JST, based on a 24-hour clock.

2 FACTUAL INFORMATION

2.1 History of the Flight

On February 10, 2009, a Bell 206L-3, registered JA6055, (hereinafter referred to as “the Aircraft”) operated by Shin Nihon Helicopter Co. Ltd. (hereinafter referred to as “the Company”), took off from a temporary helipad in Numata City, Gunma Prefecture (hereinafter referred to as “Numata Helipad”) around 9:38 for transmission line inspection flight (hereinafter referred to as “the Inspection Flight”) with a pilot in command (PIC) in the right seat and a transmission line inspector (hereinafter referred to as “the Inspector”) in the left seat. The inspection mission of Minakami line (hereinafter collectively referred to as “Grid A”) originates at Yujuku substation in Minakami-machi.

The flight plan submitted to Tokyo Airport Office, Tokyo Regional Civil Aviation Bureau, Ministry of Land, Infrastructure, Transport and Tourism was outlined below:

Flight rules: VFR, Departure Aerodrome: Numata temporary helipad, EOBT: 09:40, Cruising speed: 30kt, Cruising altitude: VFR, Route: Yujuku, Kamimoku, Naramata, Destination Aerodrome: Numata temporary helipad, Purpose of flight: Transmission line inspection, Total EET: 1 hour 10 minutes, Endurance: 2 hours and 30 minutes, POB: 2.

The history of the flight up until the accident occurred was stated by the PIC and the Inspector as follows.

(1) PIC

I checked the weather conditions after arriving at Numata Helipad. After finding weak wind and few cloud cover over mountains, I made a phone call to an office of transmission line maintenance group of an electric power company ordered the flight, which is located in Numata City, saying the 9:30 flight would be possible. I made a pre-flight check and confirmed the Aircraft had no anomalies.

After the arrival of the Inspector, we had a meeting checking key items following a preflight checklist for the Inspection Flight. As we were supposed to inspect Grid A in the first flight, we confirmed how we fly over Yujuku substation, how we deviate a ranch near tower 42², and how we fly over the point where transmission lines of a railway company (hereinafter collectively referred to as “Grid B”) intersects over the grid we inspect (hereinafter referred to as “the Overhead Intersection”).

We took off the helipad at 9:38 and started our mission from Yujuku substation. I

² Each tower is equipped with an identification plate to show its tower number. Each tower is called with its tower number.

deviated right to avoid the ranch before getting to tower 42 and returned to the inspection route but I couldn't confirm the tower's serial number shown on each tower. But I was sure that we would come to the Overhead Intersection some distance away. I looked at a route map of the inspection route (hereinafter referred to as "the Route Map") and kept flying along Grid A, checking the tower's serial numbers, and tower 36 came into view. I thought there should be the Overhead Intersection ahead but I could not find Grid B. With the spotting of Grid B I would increase altitude; my course of action then was to reduce airspeed and increase altitude. As I could not spot Grid B even after I passed tower 36, I was at a loss and thought "Was tower 36 actually tower 38? If so, I may have not still reach the Overhead Inspection". I checked the Route Map again, shifted my vision forward and spotted Grid B. I banked the Aircraft to the right instinctively and it maneuvered almost parallel to Grid B. I could not stop the forward inertia and the Aircraft seemed to touch one of transmission lines of Grid B. I could not figure out which part of the Aircraft touched Grid B, I felt we were kind of trapped by it. I deepened the bank angle and we were freed from it. I could not recall exactly what happened next, I guess at some point we were hovering, then the Aircraft began to yaw slowly to the right. I tried to stop yawing movement and I temporarily succeeded in that, however, the Aircraft tilted to the left and fell in uncontrollable situation right after that. Then the Aircraft crashed.

When I came to my mind the engine was stopped and engine-out warning was beeping. The Inspector was in agony. While I was unbuckling the safety belt and wondering what to do in order to ease his pain, he unbuckled his safety belt and crawled out of the Aircraft. After I get out of the Aircraft, I informed my company and nearby fire station of the crash with cell phone. Someone who rushed to our place let me know the leaking fuel and I turned off generator switch, battery switch and other related switches.

While I wasn't able to spot Grid B I should have stopped advance or asked my left seat occupant where we were, but I prioritized finding Grid B by myself. I couldn't see towers which support transmission lines of Grid B.

Each tower has some sign boards. I don't make call-out every time I see them. But when we need to deviate from inspection route I make a call-out to alert an inspector.

I was not in bad physical or mental condition that day. We were supposed to cover three observation courses that day, however, we weren't time-driven to cover the next course.

(2) Inspector

I arrived at Numata Helipad around 9:15 and did a preflight meeting based on the Route Map and confirmed deviation points and other points of concern. We took off from the helipad around 9:40 and started the Inspection Flight after flying over Yujuku substation, our starting point. When we reached tower 44, I jotted down the condition of the serial number

placard – it was weathered and indistinct. After we deviated from the ranch we resumed our inspection then I saw tower 37. I couldn't see the serial number attached on the previous tower, tower 38. We flew along towards towers 36 and 35. As outgrown trees under the transmission line near tower 36 was supposed to be cut in the near future, I was looking down at the foliage and taking notes for the future work. Suddenly the Aircraft began climbing. I wasn't able to grasp the situation. When I looked forward I saw an overhead ground line and heard banging noises, I thought we had a hit. After the hit the Aircraft banked and turned to the right and become parallel to Grid B. Then we faced off Grid B. I felt we were trapped, being pulled back and we were not released at once. The PIC was trying to get away from the transmission line and upon the release the Aircraft descent leftward and crashed to the ground. After the crash I was dazed for a while but came to my mind due to the fume of fuel and I crawled out of the Aircraft. However, I couldn't move any more due to severe pain. The PIC seemed to have made phone calls to the Company and a fire station using his cell phone. Later I also made a phone call to my company.

I've been in the work of power grid inspection by helicopter for about 30 years. As I had worked at Numata office several times, I was familiar with the inspection route. My experience says an inspection helicopter usually deviates to the right near tower 36 or 37 and fly over a tower of Grid B.

We don't have safety classes for boarding a helicopter. I, from my experience, tried to make voluntary call-outs when we got near to obstacles or places of danger; this time my attention was directed to the area of foliage to be cleared and I didn't do that. I don't know how the PIC was trying to spot Grid B. He didn't ask me a question about Grid B.

I think the background of Grid B at the time of my sighting was sky.

During the preflight meeting I didn't mention my need to check the foliage condition near tower 36, which is supposed to be cleared.

The accident occurred around 9:53 at the mulberry field near the overhead intersection where Grid A intersects Grid B (36° 42' 52"N, 138° 57' 57"E).

(See Figure 1 Estimated Flight Route, Figure 2 Accident Site Layout, Figure 3 Inspection Route and Tower Configuration, Photo 1 Accident Site, Photo 2 Accident Aircraft (forward fuselage)

2.2 Injuries to Persons

The PIC sustained broken lumber vertebrae. The Inspector sustained broken lumber

vertebrae and viscerocranium.

2.3 Damage to the Aircraft

2.3.1 Extent of Damage

The Aircraft destroyed.

2.3.2 Damage to the Aircraft Components

Fuselage and Tailboom :	destroyed
Landing gears:	destroyed
Main rotor blades:	one was separated and the other was destroyed
Main rotor mast:	separated
Engine:	damaged
Tail rotor blades:	separated

2.4 Other Damage

One of the transmission lines of Grid B - the lowest line on the west side (hereinafter referred to as "Line C") was cut and hung over Grid A. This caused a power outage for about four hours, affecting roughly 17,000 households and two local train operations of JR Joetsu Line.

2.5 Personnel Information

PIC Male, Age 35

(1) Certificate and flight hours

Commercial pilot certificate (Rotorcraft)

Rating: Land Single-Turbine

Issued on August 29, 2001

Class 1 aviation medical certificate

Validity

December 2, 2009

Total flight time

1,615 hours 17 minutes

Flight time in the last 30 days

31 hours 38 minutes

Total flight time on the type of aircraft

304 hours 45 minutes

Flight time in the last 30 days

31 hours 38 minutes

(2) Training and job experience

a. After promoting to the PIC status the PIC had logged about 90 hours for on-the-job (OJT) training for inspection areas since January 16, 2008.

The OJT on Grid A was done on February 25, 2008. The flight was done flying

having safe distance and altitude from the grid and the confirmation was made on the Overhead Intersection and area's geographical features.

b. The PIC's job experience for the Inspection Flight was about 190 hours.

2.6 Aircraft Information

2.6.1 Aircraft

Type	Bell 206L-3
Serial number	51393
Date of manufacture	August 6, 1990
Certificate of airworthiness	No.TOH-20-346
Validity	October 26, 2009
Category of airworthiness	Rotorcraft Category N/Special category X
Total time in service	5,342 hours 11 minutes
Time in service since last periodical check (October 10, 2008)	80 hours 31 minutes

(See Figure 4 Three-Angle-View of Bell 206L-3)

2.6.2 Weight and Balance

The weight of the Aircraft at the time of the accident was estimated to be approximately 3,500 lb, with the position of center of gravity at 121.8in. aft of the reference point and 0.3in right of center line. It is estimated that each of them were within the allowable limits. (cf. Maximum certified weight is 3,553 lb. Allowable center of gravity range corresponding to this weight is between 118.5 - 127.7 in. in longitudinal axis and 3.5 in. left - 4.0 in. right in lateral axis.)

2.6.3 Fuel and Lubricant

The fuel was Aviation fuel Jet A-1 and the lubricant was Mobile Jet Oil 254.

2.7 Meteorological Information

The PIC mentioned that the meteorological conditions at the time of the occurrence was fair with few cloud cover over mountains, with visibility of more-than-10 km and weak wind.

2.8 Information on Accident Site and Wreckage

2.8.1 Accident Site

The accident site was the mulberry field on a slope in Minakami-machi, Gunma Prefecture, which faces east with broad-leaved forest to the north and terraced paddy fields to the south. Grid B intersects Grid A and runs above it about 90 m east of the accident site.

The Aircraft lied leaning about 45° to the left from the upright position facing to the east. Mulberry tree canopies near the Aircraft exhibited slashed appearances.

About 4 m east of the Aircraft there sat a main rotor component: a mast separated at the point about 1.2 m from its top and two main rotor blades. There were ground scars made by main rotor blades nearby. Main rotor blade (red³) was bent. Main rotor blade (white) was separated at the point about 1 m from its hub and the separated portion was found in a terraced paddy field about 95 m south-east from the Aircraft.

There were ground scars made by tail rotor blades on the ground under the tail rotor. A blade tip of one tail rotor blade and a separated blade component of the other blade were found about 90 m east and 40 m west of the Aircraft respectively.

Transmission line C was cut near the insulator installed on tower 117.

As shown on Figure 3, the slope east of tower 42 descends to the east and the Overhead Intersection is located in lower part of the slope. As shown on Figure 1, from tower 36 one can see the west slope of Mitsumine mountain range. The upper part of the west slope is higher than tower 36 by 200 – 400 m.

(See Figure 1 Estimated Flight Route, Figure 2 Accident Site Layout, Figure 3 Inspection Route and Tower Configuration)

2.8.2 Detailed Information on Damages

(1) Fuselage and tailboom

The fuselage was damaged as if it were crushed from above and was inclined about 45° to the left from the upright position. The forward left part of lower fuselage, ranging from the nose section to the cabin section, was substantially damaged.

The forward part of the left elevator was damaged by tree at the accident site.

The fuselage and the tailboom exhibited no contact marks with a transmission line.

(2) Landing gears

The forward cross tube was bent leftward at the attaching point to the fuselage and forward end of the left skid was situated near the cockpit. The aft cross tube deformation was

³ Main rotor blades and tail rotor blades are color coded for identification purpose.

minor. Although both skids were not separated from the cross tubes, the right skid was situated away from the fuselage and the left skid was placed under the fuselage.

(3) Main rotor blades

The red blade was bent at the point about 1.7 m from its hub and its tip was damaged.

Major part of the white blade (length about 3.3 m) was separated at the point about 1 m from its hub. On the under surface of the separated portion, striped fine scratch marks were found near the leading edge in the area of about 1 m from the tip.

(4) Main rotor mast

The main rotor mast was separated near the top of the main transmission.

(5) Engine

The main driveshaft was disjoined at the entrance to the main transmission.

The power turbine and gas producer turbine were turned by hand without seizure.

(6) Tail rotor blades

The inner surface (tailboom side) of both blades exhibited striped copper-colored fine scratch marks.

The end of the red blade was separated. It was bent in the middle section. The area up to about 10 cm from the outer end on inner surface exhibited scaled paint and striped fine scratch marks.

The white blade was separated at the point about 15 cm from the hub. The area near the leading edge of inner surface, up to about 30 cm from the tip was flattened and the airfoil property was compromised.

(7) Result of scratch mark ingredient analysis on the main rotor blade and the tail rotor blades

The metallic material found on striped fine scratch marks was analyzed to be copper. (See Picture 1 Accident Site, Picture 2 Accident aircraft (forward fuselage), Picture 3 Contact Marks on Transmission Line C, Picture 4 Contact Marks Near Leading Edge of Main Rotor Blade (white), Picture 5 Contact Marks on Inner Surfaces of Both Tail Rotor Blades)

2.9 Information on Search and Rescue

9:55 The Company received a phone call from the PIC on the accident.

The company forwarded the information to Tokyo Regional Civil Aviation Bureau at 9:58 and requested the police helicopter squad of Gunma prefecture to rescue the occupants.

10:02 Nishi Fire Station, Tone-Numata Area Fire Brigade received an emergency phone call from the PIC requesting the rescue of two occupants of a crashed helicopter.

10:15 A Police helicopter located the accident site and confirmed the condition.

10:25 Fire brigade crew boarded two occupants in an ambulance and transported them to a hospital in Numata city.

Tokyo Rescue Coordination Center (set up in Tokyo Airport Office in Haneda Airport) launched a search and rescue operations at 10:04 upon receiving the information from Tokyo Regional Civil Aviation Bureau. It terminated the operations at 11:05 after confirming the discovery of the Aircraft and the rescue of the occupants.

2.10 Additional Information

2.10.1 Inspection Flight Procedures

The procedure of transmission line inspection flight is stipulated in the Company's flight operations manual and affiliated operational standards. Excerpts of the operational standards are shown in italic as follows.

4 Periodical Inspection Flight

(1) Things to be checked in advance

a. NOTAM and other information on concerning area

(2) Before take-off

a. Weather en route and at the destination

(3) Before take-off meeting

a. Meetings progress confirming the items listed on the "Pre-flight Checklist" using a course map or a grid map.

(5) Inspection flight

a. A prior map study of a course is necessary. A PIC and an inspector make acknowledgement of a starting point.

c. Close communication with an inspector is necessary. A PIC makes call-outs when he maneuvers an aircraft to evade obstacles.

(6) Maneuver

a. Position an aircraft to the right of transmission lines.

h. When crossing transmission lines, fly over a tower with ample clearance for safety keeping an inspector free of uneasiness.

i. When noise complaint is expected from densely housed areas, ranch and the like, climb or deviate the course for noise abatement.

(7) *Position of a helicopter to transmission lines*

(Relative position of the Aircraft for Grid A inspection is shown here)

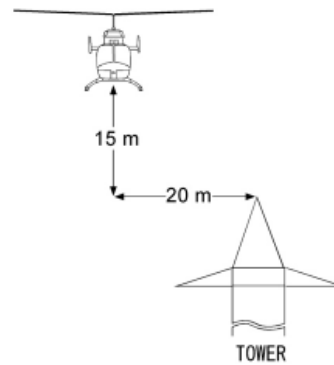

(8) *Airspeed for inspection*
50 km/h

7 Tower placards

(1) *Safety placard*

a. *Serial number placard*

(25 cm (length) by 45 cm (width))



(3) *Intersection placard*

The top of the tower which has an intersection placard is painted in orange. The placard is attached on towers on both sides of the overhead intersection, which are located about 500 m away from the intersection.

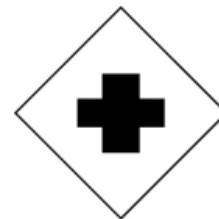

(35.5cm by 35.5cm)

2.10.2 Helicopter Operations Manual of the Electric Power Company

The electric power company stipulates a “Helicopter operations manual” as a standard for transmission line inspection flight. Excerpts of concerning portion are shown in italic as follows.

8. *Preparation for a flight*

(4) *Arrangement with a PIC*

a. *Locations where other transmission lines intersect the flight route (special attention to overhead intersection) and how they are depicted on the map.*

10. *Advices to a PIC*

(1) *An inspector makes advices/requests to a PIC on the following matters. The execution rests in discretion of a PIC with his consideration of helicopter performance and geographical features.*

a. *Notification to a PIC on nearing grid intersections or obstacles.*

Note 3 The designated area of non-inspection

This is the area where flight inspection of transmission lines and the neighboring area are skipped. It is permissible to fly in the vicinity of the area, however, in case of doing so gain altitude or detour the area. The specific examples are:

a. The area where overhead structures cross a subject transmission lines.

2.10.3 Information of the Towers Supporting Grid A

Configurations of towers from 38 to 35 are as follows.

- (1) Each tower is equipped with a serial number placard.
- (2) No. 38 is the only tower which is equipped with an intersection placard.
- (3) Top of towers 36 and 35 are painted in orange.
- (4) Tower 36 stands about 610 m above sea level (Measured at the base of a tower.

Same applies to other towers.) with its own height of about 27 m. Tower 35 stands about 570 m above sea level with its own height of about 32 m.

(See Figure 3 Inspection Route and Tower Configuration)

2.10.4 Information on Grid B

(1) Individual transmission line of Grid B is made up of 19 twisted hard copper strands and its diameter measures about 2 cm.

According to the railway company, the post restoration measurement revealed that Line C had contact marks with the helicopter about 85 m south from the tower 117, with the above-ground-level (AGL) altitude of 44.9 m, and that the vertical distance between Line C and the upper-most ground line measured 12.6 m.

Given the ground elevation of the contact marks to be about 565 m, contact marks' elevation is calculated to be about 610 m.

Incidentally Grid B and its supporting towers 117 and 118 does not fall into the category of structures which are required to install obstacle markings under the Article 51-2, Civil Aeronautics Act with the following reasons.

a. Towers 117 and 118 are 30.5 m and 32.6 m tall respectively, and they don't fall in the category of mandatory towers which are more than 60 m tall.

b. The contact marks on the transmission line were less than 60 m AGL ($44.9+12.6<60$). Although the AGL measurements of other parts of the Line C between both towers are unknown, this part does not fall in the mandatory section in the directive issued by the Minister of Land, Infrastructure, Transport and Tourism, based on the applicable conditions of transmission lines stipulated in the Article 132-2-1-3, Civil Aeronautics Regulations.

(See Picture 3 Contact Marks on Line C)

(2) The railway company's facility detected the power outage at 09:53.

2.10.5 Ordinary Maneuver of Crossing Transmission Lines

The HUMAN A.D. issued by Bell Helicopter Textron Inc on November 2, 2004. stipulates on "Wire Avoidance" as follows. (Excerpt)

Cross at a tower and never in mid-span, even on a routine patrol and especially when flying cross-country---especially in low visibility.

2.10.6 Permissions related to the Civil Aeronautics Act

Provisory permissions under the Civil Aeronautics Act were obtained on take-offs and landings other than airports (Article 79) and flights under the safety altitude (Article 81).

2.10.7 Installation of an Emergency Locator Transmitter

The Aircraft was installed with a Emergency Locator Transmitter (ELT) .

3. ANALYSIS

3.1 The PIC held both valid airman competence certificates and valid aviation medical certificates.

3.2 The Aircraft had a valid airworthiness certificate and had been maintained and inspected as prescribed.

3.3 It is considered highly probable that the weather condition at the time of the accident had no bearing on the occurrence of the accident.

3.4 How the Aircraft Contacted with Grid B

It is certain that the Aircraft made a contact with Line C judging from the following facts: as described in 2.10.4(1) individual transmission line of Grid B is made up of twisted hard copper strands; as described in 2.8.2(7) the metallic material found on striped fine scratch marks on the main rotor blade and the tail rotor blades was analyzed to be copper and as described in 2.1(1) the PIC stated that he had made a contact with Grid B.

Because above mentioned scratch marks were found on flat areas on each blade, not on the forward edge, it is considered highly probable that each blade made contacts with the Line C as a plane. It is also considered highly probable that, during the contacts the inner surface of both tail rotor blades, the area stretching as long as 30 cm from the tip, were flattened.

As the PIC stated that when he maneuvered the Aircraft to escape from Grid B he felt something caught the Aircraft, it is considered probable that the Line C was separated at tower 117 by the pull generated by the tail rotor rotating plane in contact with the transmission line.

3.5 Uncontrollable State Experienced by the Aircraft

The PIC stated the events following the contact with Line C as follows in 2.1(1). "I guess at some point we were hovering, then the Aircraft began to yaw slowly to the right. I tried to stop yawing movement and I temporarily succeeded in that, however, the Aircraft tilted to the left and fell in uncontrollable situation right after that. Then the Aircraft crashed."

Because the tail rotor impact marks lie on the ground, it is considered probable that the destruction of the tail rotors took place at the impact against the ground. Likewise a main rotor impact marks lie on the ground, it is considered probable that separation of white blade took place at the impact. Given the scratch marks on main rotor blade, it is considered

probable that its contact with Line C lasted for a very short time and the deformation was not severe enough to affect the maneuver of the Aircraft. As for the tail rotor effectiveness, it is considered probable that the deformed airfoils reduced generated thrusts.

It is considered highly probable that the PIC pulled collective lever and transitioned the Aircraft to a hovering in order to arrest altitude loss and to stabilize the Aircraft after being released from Line C. At this moment the tail rotor blades could not produce enough thrust to counter anti-torque, generating right yaw in spite of left pedal input.

The PIC stated that he then temporally succeeded in stopping the yaw and stabilizing the Aircraft but it fell into the uncontrollable state and crashed. It is considered possible that he lowered the collective lever and lowered the nose of the Aircraft in order to maneuver forward and employ the vertical fin's effect, but in order to increase airspeed he pulled the collective lever regenerating right yaw and this developed into uncontrollable state. It is considered highly probable that the Aircraft did not have enough altitude to get out of the situation at this moment and crashed to the ground.

3.6 Developments until the Contact with a Transmission Line

(1) Returning to the inspection route after deviating the ranch

The PIC was neither able to confirm where he resumed the Inspection Flight nor asked a question to the Inspector while the Inspector knew that the Aircraft resumed the Inspection Flight near tower 37. But he did not inform this to the PIC. It is considered probable that this lead to the PIC's confirmation of the serial number of the tower nearest to the Overhead Intersection on the Route Map.

(2) Around the passing of tower 36.

When the PIC confirmed tower 36 he was looking for Grid B because the Overhead Intersection was ahead of his location. The Inspector stated that an inspection helicopter usually deviates to the right near tower 36 or 37 and fly over a tower of Grid B. It is considered highly probable that the PIC continued fly straight without deviating to the right near tower 36, against widely practiced procedure. It is considered probable that as a consequent he could not find Grid B and kept flying descending along Grid A while the Inspector's attention was directed to trees to be cut and he could not advise him of present position.

It is considered probable that the PIC, unable to find Grid B in spite of reducing the airspeed for safety, started to climb.

The PIC stated that he was wondering whether the previous tower he passed was 38 or 36. Tower 36's top is painted in orange and differentiating from tower 38 was considered possible, however, it is considered possible that the PIC was not capable of paying enough

attention to the coloring of the painting. At this stage he should have stopped advance to locate present position or asked the Inspector about their whereabouts, however, he did neither of them.

(3) In the vicinity of Grid B

It is considered highly probable that as stated in 2.1(1), the PIC turned his eyes to the inside of the cockpit to confirm the Overhead Intersection on the Route Map and just after the shift of his vision to the outside he found Grid B ahead of the Aircraft and took an quick evasive maneuver, however, the Aircraft contacted Line C. The altitude then was estimated to be about 610 m. The Inspector visually recognized the upper ground line of Grid B.

If the vertical safety margin of 20 m were taken as described in 2.10.4, the Aircraft should have climbed additionally 32.6 m, given the vertical distance of 12.6 m between Line C and the upper ground line. The PIC stated that he maneuvered the Aircraft to climb, however, it is considered highly probable that it was not done appropriately. It is considered probable that the flying along the descending slope affected the PIC's sense of climb and even flying level would be felt as climbing maneuver and this lead to the improper altitude gain.

3.7 Spotting of Grid B

As described in 3.6, the elevation of Line C with which the Aircraft contacted was about 610 m above sea level. Compared with this elevation to that of western slope of the Mitsumine mountain range, the latter's elevation is higher. The PIC was flying along down-slope with the west slope of the mountain range in dark color of deciduous trees ahead of it. It is considered probable that Grid B's blending in the back ground contributed to the delayed spotting of Grid B by the PIC.

On the other hand the Inspector stated that the back ground of Grid B was sky. Given the fact that he saw the upper ground line at the very moment of climbing just before the contact with Grid B, it is considered probable that the back ground was the sky as stated.

The reason why the PIC did not deviate to the right near tower 36 is considered to have attributed by the following elements: in addition to the attention allocated to helicopter operations, he was obsessed with the feeling that the Aircraft was nearing the Overhead Intersection and his attention was solely shifted to spotting the transmission lines thus being unable to stretch out his attention to finding towers which help locate transmission lines.

3.8 Flying over Transmission Lines

As described in 2.10.2 the rule enabled the helicopter to detour the designated area of non-inspection. It is considered highly probable that if the PIC swayed his vision to the left

and the right near tower 36 to find the towers which support Grid B as described in 2.10.5, detouring the route to fly over the supporting tower, he could have secured safety clearance and escaped to have contacted with the transmission line.

3.9 Cockpit Communications

The flight operations manual described in 2.10.1 stipulates that *close communication with an inspector is necessary and a PIC makes call-outs when he maneuvers an aircraft to evade obstacles*. When the PIC resumed inspection near tower 38 or 37 and when he had a question near tower 36, he did not ask the Inspector the serial number of the tower. With these considered it is probable that the cockpit communications were insufficient.

On the other hand, the electric power company's manual described in 2.10.2 requires an inspector to notify a PIC of the approaching of intersection with other grid or obstacles. It is considered probable that the Inspector, as stated in 2.1(2), usually tried to make call-outs when reaching obstacles or area of special attention, however, this time his attention was directed to trees near tower 36 and this lead to inability to alert the PIC.

3.10 Recurrence Prevention Measures

The transmission line inspection flight is considered to be difficult operations compared to an ordinary flight as the flight environment includes unfavorable conditions such as turbulent air in mountainous area of high elevation, flying close to various obstacles transmission lines at low altitude and low air speed.

Although it depends on weather conditions, maintaining aerial inspection position stabilizing aircraft for easier inspection burdens a PIC and it undeniably reduces his attention allocation to navigation. On the other hand, continued orientation is essential for safe crossing of overhead intersection and other hazardous area.

This accident was triggered by the PIC's incapacitation of proper orientation. A PIC and an inspector should, as described in the Company's flight operations manual and the electric power company's Helicopter operations manual, communicate voluntarily for safe flight.

Additionally, this accident occurred as a result of flight over the mid spun of transmission lines. It is strongly recommended that an aircraft should, as stipulated in the company's flight operations manual and Bell's document, cross at a tower.

4. PROBABLE CAUSE

In this accident, it is considered highly probable that the Aircraft, during its transmission line inspection flight, contacted one of overhead intersecting transmission lines, leading to uncontrollable situation, subsequently crashing to the ground.

With regard to the contact with another transmission line, it is considered probable that the PIC's continued advance without locating his present position under the insufficient communicative condition, and failure of spotting the transmission line in time served as contributing factors.

5. MATTERS OF REFERENCE

After the occurrence of the accident, the Company has taken the following corrective measures.

1. Revision of the flight operations manual

The following two points were added.

(1) Cross at a tower with sufficient safety margin when crossing transmission lines.

(2) When lost during inspection flight, leave the route to locate present position and resume a mission.

2. The Company developed a table of individual flight experience on each inspection route to utilize this to augment less experienced pilots. When a less experienced pilot flies an inspection mission, an experienced pilot boards an Aircraft for look-out and provision of necessary advice.

Figure 1 Estimated Flight Route

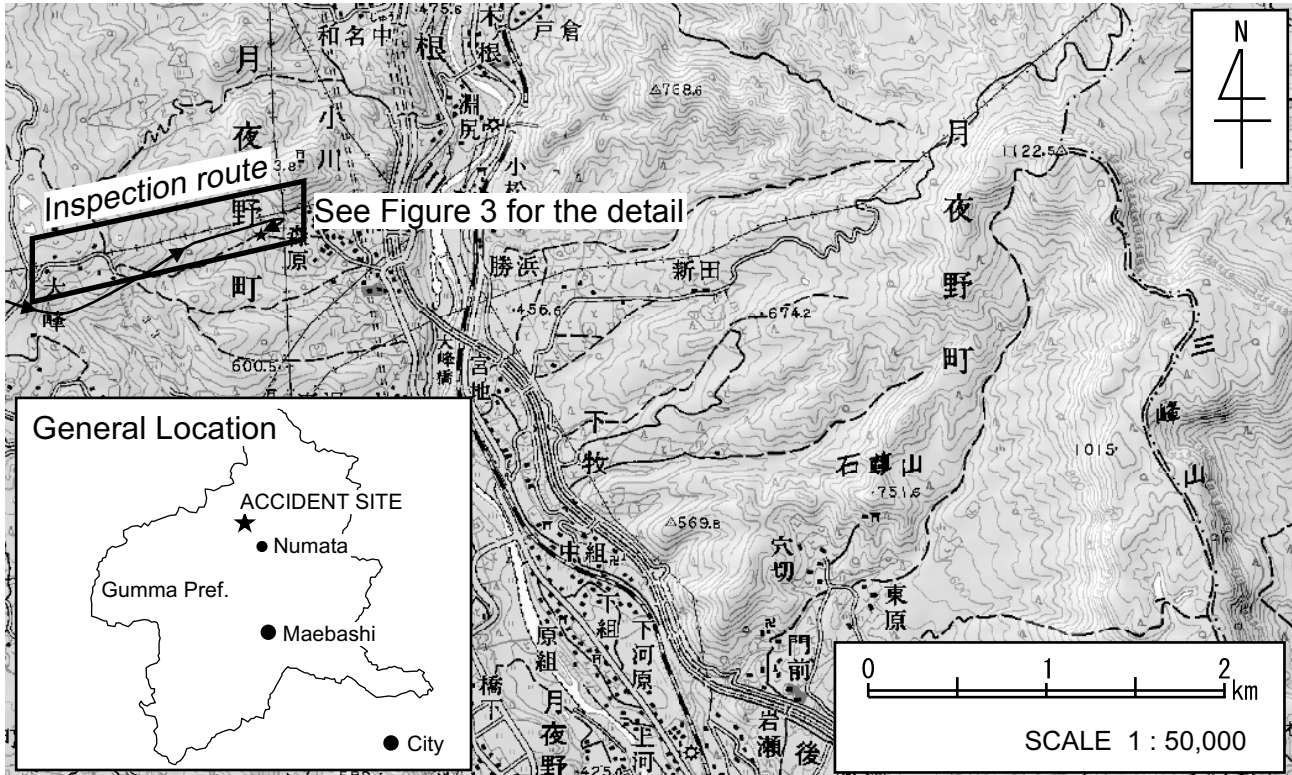

Figure 2 Accident Site Layout

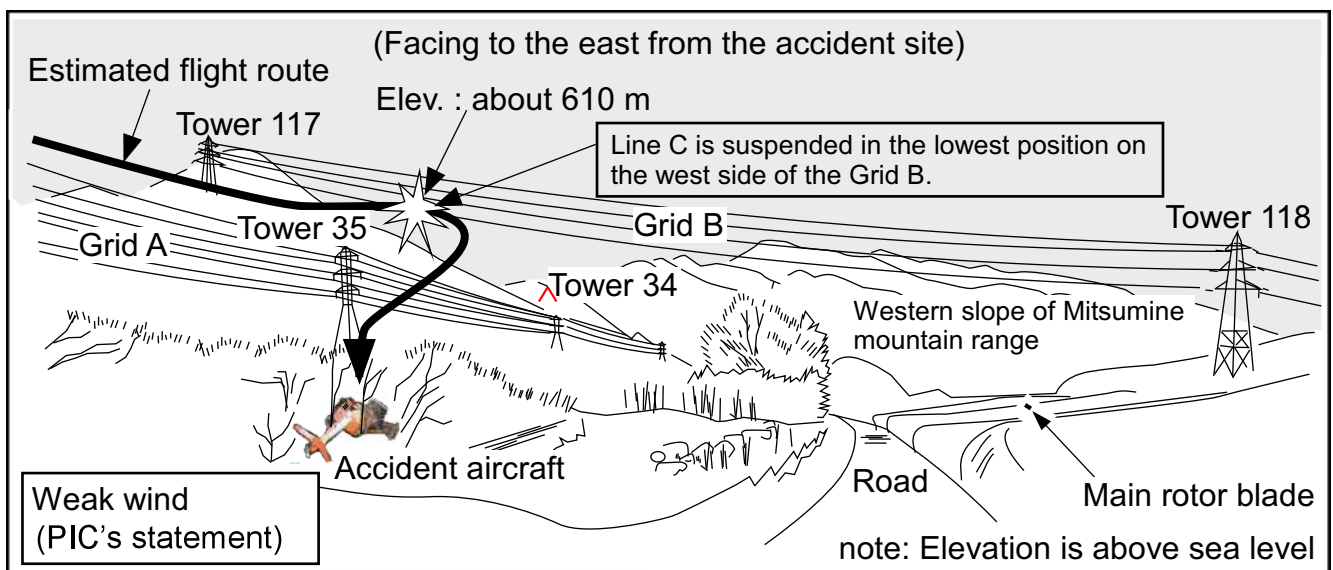

Figure 3 Inspection Route and Tower Configuration

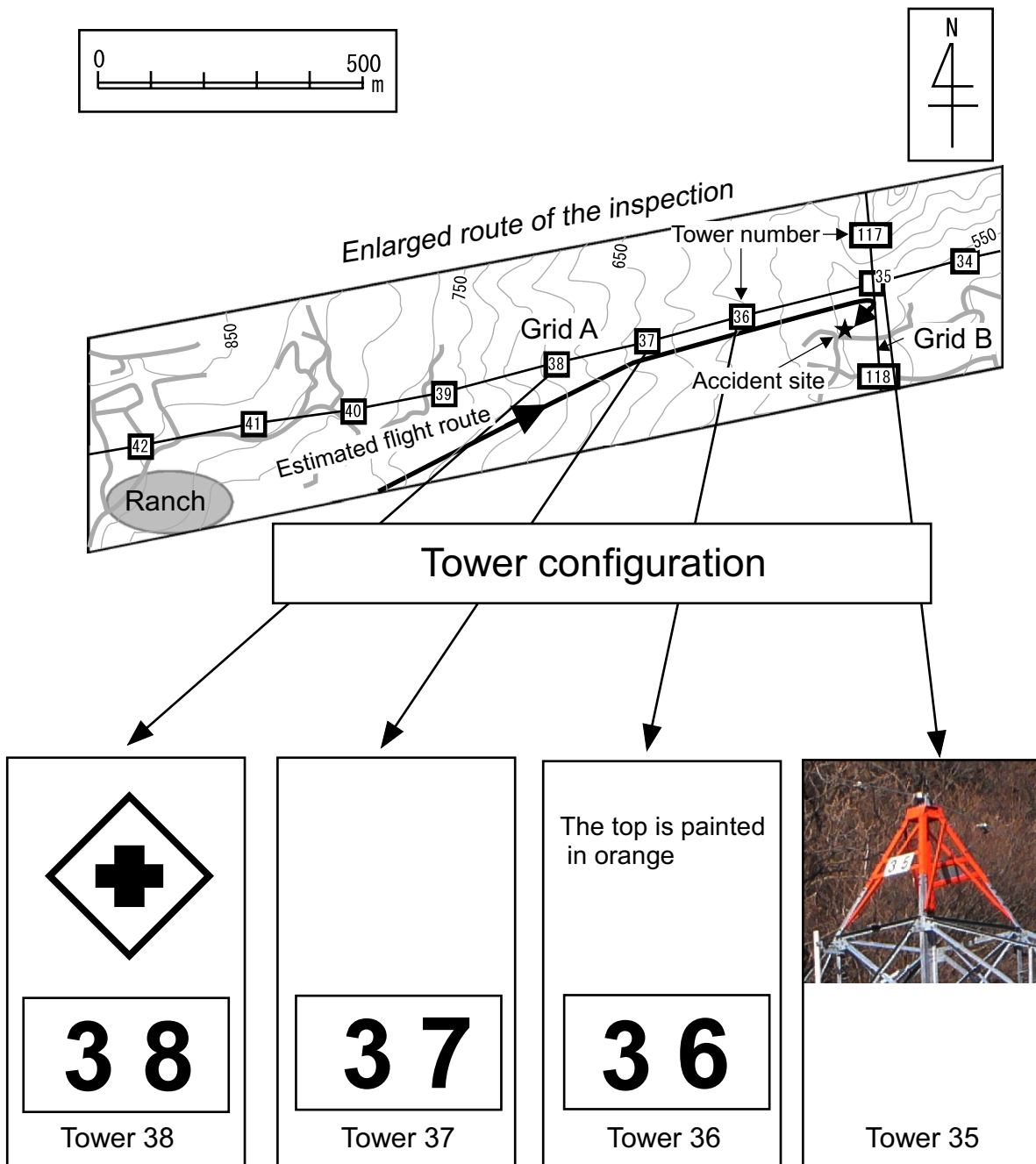
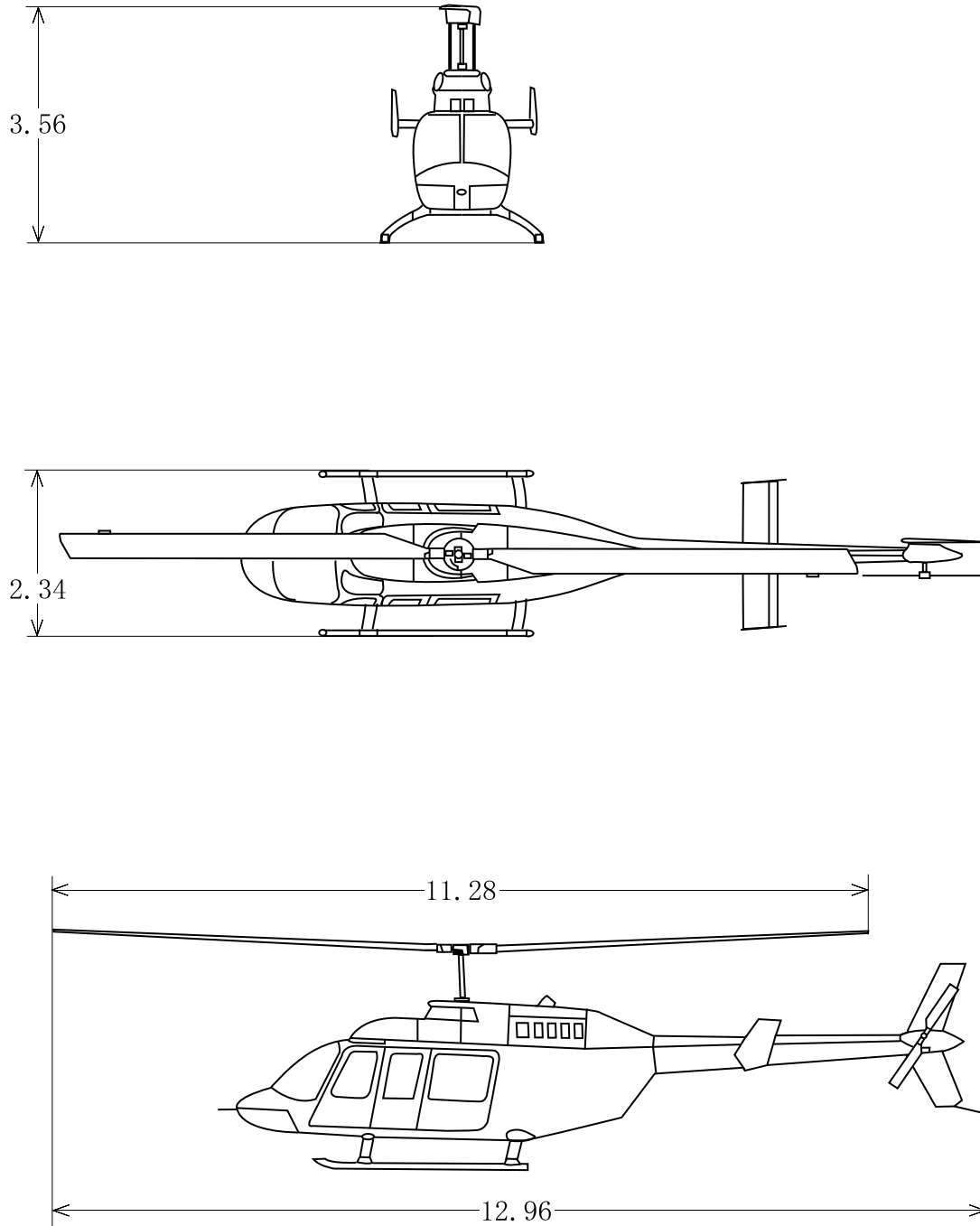

Figure 4 Three-Angle-View of Bell 206L-3

Unit : m



Picture 1 Accident Site



Picture 2 Accident Aircraft (forward fuselage)



Picture 3 Contact Marks on Line C

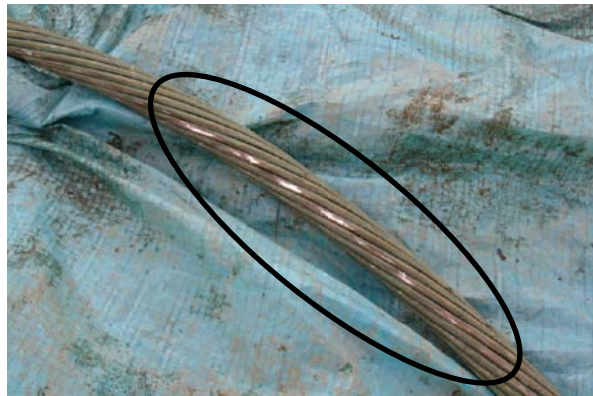

Picture 4 Contact Marks Near Leading Edge of Main Rotor Blade (white)

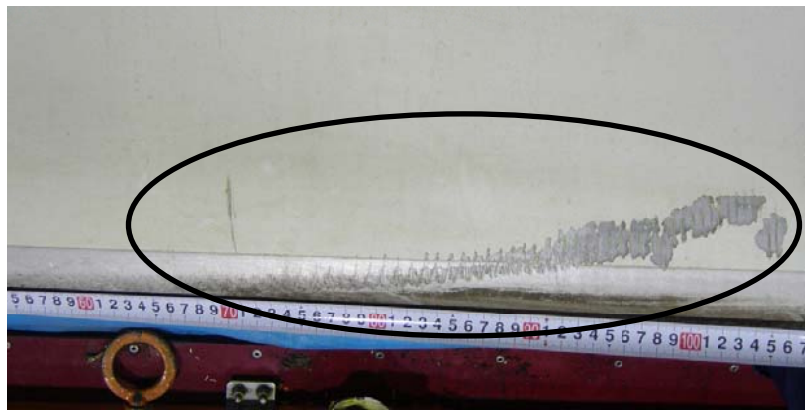

Picture 5 Contact Marks on Inner Surfaces of Both Tail Rotor Blades

