

AA2014-4

**AIRCRAFT ACCIDENT
INVESTIGATION REPORT**

ASIANA AIRLINES INC.

H L 8 2 5 8

July 25, 2014



The objective of the investigation conducted by the Japan Transport Safety Board in accordance with the Act for Establishment of the Japan Transport Safety Board and with Annex 13 to the Convention on International Civil Aviation is to determine the causes of an accident and damage incidental to such an accident, thereby preventing future accidents and reducing damage. It is not the purpose of the investigation to apportion blame or liability.

Norihiro Goto
Chairman,
Japan Transport Safety Board

Note:

This report is a translation of the Japanese original investigation report. The text in Japanese shall prevail in the interpretation of the report.

AIRCRAFT ACCIDENT INVESTIGATION REPORT

PASSENGER INJURY BY THE SHAKING OF THE AIRCRAFT
ASIANA AIRLINES INC.
AIRBUS A330-300, HL8258 (THE REPUBLIC OF KOREA)
AT AN ALTITUDE OF APPROX. 40,000 FT, OVER MATSUE CITY,
SHIMANE PREFECTURE, JAPAN
AT AROUND 15:17 LOCAL TIME, AUGUST 21, 2012

June 27, 2014

Adopted by the Japan Transport Safety Board

Chairman	Norihiro Goto
Member	Shinsuke Endoh
Member	Toshiyuki Ishikawa
Member	Sadao Tamura
Member	Yuki Shuto
Member	Keiji Tanaka

SYNOPSIS

<Summary of the Accident>

On Tuesday, August 21, 2012, an Airbus A330-300, registered HL8258, operated by Asiana Airlines Inc., took off from Honolulu International Airport, the United States of America, for Incheon International Airport, the Republic of Korea, as a scheduled flight 231. While flying at approximately 40,000 ft over Matsue City, Shimane Prefecture, around 15:17 Japan Standard Time (JST: unless otherwise stated all times are indicated in JST, UTC+9h), the aircraft was shaken. Two passengers were seriously injured and one passenger was slightly injured.

There were 221 people on board, consisting of the pilot in command (PIC), 14 other crew members and 206 passengers.

The aircraft was not damaged.

<Probable Causes>

It is highly probable that in this accident, serious injury was sustained by a passenger walking in the rear aisle due to the severe shaking of the Aircraft, and that serious injury was sustained by another passenger seated nearby when the passenger removed the seat belt in order to help the injured passenger, the Aircraft shook severely again at that moment.

It is probable that the initial severe shaking of the Aircraft was a result of the Aircraft passing through or nearby cumulonimbus, due to the PIC and the R Captain failing to notice that the weather radar was off, and encountering atmospheric disturbances with severe changes in wind direction and speed coupled with strong updrafts. It is possible that the next shaking of the Aircraft may have been influenced by the PIC's control operations after disengaging the A/P to stabilize the aircraft.

It is probable that the reason for the PIC and the R Captain failing to notice that the weather radar was off was that their monitoring of the weather conditions and instruments was insufficient.

Abbreviations used in this report are as follows:

ACC: Area Control Center
AOA: Angle of Attack
A/P: Auto Pilot
CB: Cumulonimbus
CRM: Crew Resource Management
CVR: Cockpit Voice Recorder
DFDR: Digital Flight Data Recorder
FCOM: Flight Crew Operating Manual
FCTM: Flight Crew Training Manual
FCU: Flight Control Unit
FL: Flight Level
FOM: Flight Operations Manual
G: Gravitational Acceleration
IMC: Instrument Meteorological Conditions
MAC: Mean Aerodynamic Chord
MMO: Maximum Operating Limit Speed in Mach
ND: Navigation Display
OCC: Operation Control Center
PF: Pilot Flying
PIC: Pilot In Command
PM: Pilot Monitoring
REP: Reporting Point
RVSM: Reduced Vertical Separation Minimum
SAT: Static Air Temperature
TACAN: Tactical Air Navigation System
VLS: Lowest Selectable Speed
VMO: Maximum Operating Speed/Velocity
VOR: Very High Frequency Omni-Directional Radio Range
VORTAC: VOR and TACAN
WAFC: World Area Forecast Center

Unit Conversion Table

1ft: 0.3048m
1G: 9.807 m/s²
1kt : 1.852km/h(0.5144m/s)
1lb: 0.4536kg
1in: 25.40mm
1nm: 1.852km

1. PROCESS AND PROGRESS OF THE ACCIDENT INVESTIGATION

1.1 Summary of the Accident

On Tuesday, August 21, 2012, an Airbus A330-300, registered HL8258, operated by Asiana Airlines Inc., took off from Honolulu International Airport, the United States of America, for Incheon International Airport, the Republic of Korea, as a scheduled flight 231. While flying at approximately 40,000 ft over Matsue City, Shimane Prefecture, around 15:17 Japan Standard Time (JST: unless otherwise stated all times are indicated in JST, UTC+9h), the aircraft was shaken. Two passengers were seriously injured and one passenger was slightly injured.

There were 221 people on board, consisting of the pilot in command (PIC), 14 other crew members and 206 passengers.

The aircraft was not damaged.

1.2 Outline of the Accident Investigation

1.2.1 Investigation Organization

On August 23, 2012, the Japan Transport Safety Board designated an investigator-in-charge and an investigator to investigate this accident.

1.2.2 Outsourced Investigation

As part of the accident investigation, analytical investigation of weather information was outsourced to Electronic Navigation Research Institute and Tokai University.

1.2.3 Representatives of the Relevant States

An accredited representative from France, as the State of Design and Manufacture of the aircraft involved in the accident, and an accredited representative from the Republic of Korea, as the State of the Operator of the aircraft involved in this accident, participated in the investigation.

1.2.4 Implementation of the Investigation

August 31, 2012	Interviews
September 5, 2012	Interviews
September 10, 2012	Interviews
September 17, 2012	Interviews

1.2.5 Comments from Parties Relevant to the Cause of the Accident

Comments were invited from parties relevant to the cause of the accident.

1.2.6 Comments from the Relevant States

Comments were invited from the relevant States.

2. FACTUAL INFORMATION

2.1 History of the Flight

On Tuesday, August 21, 2012, at 07:14, an Airbus A330-300, registered HL8258 (hereinafter referred to as “the Aircraft”), operated by Asiana Airlines, Inc. (hereinafter referred to as “the Company”), took off from Honolulu International Airport for Incheon International Airport as a scheduled flight 231.

The outline of the flight plan for the Aircraft was as follows:

Flight rules:	Instrument flight rules
Departure aerodrome:	Honolulu International Airport
Estimated off-block time:	07:10
Cruising speed:	M081
Cruising altitude:	FL*1 360
Route:	(Omitted) ~ CVC (Choshi VORTAC) ~ JEC (Miho VORTAC) ~ G585 (Airway) ~ BULGA (REP) ~
Destination aerodrome:	Incheon International Airport
Total estimated elapsed time:	8 hours and 56 minutes
Alternate aerodrome:	Gimpo International Airport

There were a total of 221 people on board: a PIC, 14 crew members, and 206 passengers.

The PIC, the Route Captain*2 (hereinafter referred to as “the R Captain”), and the first officer (FO) were on board the Aircraft. In these three members, the PIC and the FO had responsibility for flying the Aircraft from takeoff to cruising, the R Captain and the FO had it while cruising above the Pacific Ocean, and the PIC and the R Captain had it while flying over Japan. In the cockpit at the time when the accident occurred, the PIC sat in the left seat as the PM (pilot monitoring: pilot mainly in charge of duties other than flying), and the R Captain sat in the right seat as the PF (pilot flying: pilot mainly in charge of flying).

Based on the records from the Digital Flight Data Recorder (hereinafter referred to as “DFDR”) and the Cockpit Voice Recorder (hereinafter referred to as “CVR”), the records of Air Traffic Control (ATC) communications, and the statements of flight crew members, cabin attendants, and injured passengers, the history of the flight for the Aircraft up to the time when the accident occurred is summarized below. The statements of the flight crew members, cabin attendants and injured passengers were collected by request to the Korea Aviation and Railway Accident Investigation Board (ARAIB) for interviews.

2.1.1 History of the Flight based on the DFDR Records, the CVR Records and the Records of ATC Communications

The Aircraft proceeded west over the Pacific Ocean by auto pilot (hereinafter referred to as “A/P”) according to the flight plan, and maintained the cruising altitude of FL400 from CVC to JEC.

15:14:17 Communications in Japanese were exchanged between the Tokyo ACC and another aircraft stating that JEC (Miho VORTAC) was out of

*1 “FL” stands for flight level. It is a pressure altitude expressed in hundreds of feet. This altitude is calculated from the international standard pressure datum of 1013.2 hPa (29.92 inHg), the average sea-level pressure. This expression applies to the altitudes higher than 14,000 ft in Japan.

*2 “Route Captain” as referred to by the Company is a pilot in a three-member crew formation who assumes the PIC’s duties in place of the regular Captain only during cruising flight.

service due to a lightning strike.

15:16:14 A small change of the vertical acceleration started.

15:16:24 The FCU speed selector was set at M0.78.

15:16:29 There was an operation sound of the seat belt selector (hereinafter referred to as “the Selector”) (one time).
(After 15:16:33, due to noise in the CVR recording, the operation sound of the Selector could not be distinguished.)

15:16:30 Until this time, the wind had been blowing from the right rear direction of the Aircraft at an average speed of 16 kt, it began to change in a counter-clockwise direction. Following this, a relatively large change in vertical acceleration began.

15:16:33 The SAT began to change.

15:16:36 The wind direction changed to blow directly against the Aircraft. The Aircraft’s AOA*³ increased suddenly, but there was no change to the pitch angle.

15:16:38 The wind speed became 34 kt. The speed of the Aircraft became M0.872, temporarily exceeding the M_{MO} (maximum operating speed limit: M0.86) and causing the over speed warning to sound.
The altitude of the Aircraft increased.

15:16:40 The SAT increased rapidly by 4°C, and this high value was maintained for approximately 15 seconds. The vertical acceleration became 1.88G, the highest value for this flight. The wind began to change in a counter-clockwise direction.

15:16:41 The rate of climb became approximately 3,300 ft/min.

15:16:42 The wind became a crosswind from the left, and the wind speed became 20 kt. The vertical acceleration became 0.04G, which was the greatest change during this flight.

15:16:44 Cabin attendants made a Passenger Address (PA) (in Korean and English) regarding shaking of the aircraft and fastening of seat belts. (~15:17:07)

15:16:45 The wind speed became 2 kt.

15:16:46 The wind became a tailwind, and the wind speed began to increase. The Aircraft continued to climb, and the altitude deviation alert sounded.

15:16:48 The A/P was disengaged with a button on the PIC side’s sidestick, and the A/P disengagement tone was sounded.

15:16:54 The sidestick on the PIC side was pushed forward. The pitch angle of the aircraft changed rapidly to -6.3°, while the vertical acceleration became -0.09G, the lowest value during this accident.

15:16:55 While remaining as a tailwind, the wind speed increased to a maximum of 52 kt, and as the roll angle varied within the range from 30.2° on the right side to 17.9° on the left side, the pitch angle reached

*³ “AOA” refers to the angle of attack. When a wing is located in a uniform air current, it is the angle formed by the direction of this current and the chord line. The AOA increases if the pitch angle is increased in a uniform air current, but when the air current changes, the AOA may increase even if the pitch angle does not.

a maximum of +14.8°. During this time, the input of roll and pitch by the sidestick on the PIC side changed greatly. (~15:17:30)

15:17:13 After the Aircraft reached the altitude of approximately 41,100 ft, it began to descend.

15:17:25 Cabin attendant made a PA (in Korean and English) requesting passengers to fasten their seat belts.

15:17:36 Cabin attendant made a PA (in Korean and English) requesting passengers to fasten their seat belts.

15:17:37 The A/P was engaged.

15:17:54 Cabin attendants made a PA (in Korean and English) regarding shaking of the aircraft and fastening of seat belts.

15:17:58 Although the Aircraft's weather radar had been off until 15:17:54, it was on at this time.

15:18:11 The Aircraft returned to the altitude of 40,000 ft.
The auto thrust had been engaged since takeoff.

15:18:26 The PIC reported to the Tokyo ACC that the Aircraft had encountered "Big Turbulence," ascended over approximately 1,000 ft, and then returned to FL400.

15:19:07 The R Captain instructed the cabin attendants to check on the condition of the cabin and report back.

15:29:57 The cabin attendants reported to the R Captain on injured passengers and the condition of the cabin.

15:33:44 The R Captain made an initial report to the OCC (Operation Control Center) of the Company.

Around 16:39 The Aircraft landed at Incheon International Airport.

2.1.2 Statements of Flight Crew Members

(1) PIC

At the time of the pre-flight weather briefing conducted at Honolulu International Airport, the prediction of vertical wind shear in the Japan airspace were low, and although clouds with a cloud top height of 42,000 ft were forecasted around the flight route, no significant weather such as clouds on the flight route, including where the accident occurred, was forecasted.

During the flight in the Japan airspace, under light hazy cloud conditions, there was some slight shaking of the aircraft; therefore, the seat belt sign (hereinafter referred to as "the Sign") had been turned on for some time prior to the accident.

The Aircraft began to shake just before the STAGE (REP). At this point, the R Captain turned off the Sign twice and then turned it back on. Although the Aircraft had been flying in Speed Select mode, its speed suddenly exceeded the M_{MO}, and it pitched nose up with its rate of climb becoming 2,500 ft/min. Therefore, the PIC immediately took over control, disengaging the A/P and attempting to stabilize the Aircraft manually. The PIC, however, was unable to control it as desired. The Aircraft shook severely up and down three to four times within about the range of 950 ft, and the bank angle became 30°.

After stabilizing the Aircraft, the PIC reported to the Tokyo ACC that it had encountered big turbulence near STAGE, ascended approximately 950 ft, and then

returned to its original altitude.

The PIC states that up to the accident occurrence point, even though there were light hazy clouds at the flight altitude of the Aircraft, there was no hail or thunderclouds, and that the weather radar had operated from takeoff to landing.

Although the PIC reduced the speed of the Aircraft during manual control, it did not fall below the V_{LS} , still less below the stall speed. Since it had exceeded the M_{MO} , he recorded the fact in the maintenance log book after arrival.

The weather conditions after the accident were favorable, and the Aircraft arrived at Incheon International Airport earlier than the estimated time of arrival. After arrival, ground staff took the two patients seriously injured to the airport hospital with wheelchairs.

(2) R Captain

The R Captain turned on the Sign twice at the initial stage of the shaking. Because it appeared that the speed of the Aircraft was likely to increase, the R Captain immediately set the recommended speed during turbulence of $M0.78$ into the FCU. Approximately 10 seconds after the PIC had taken over control of the Aircraft, the A/P was disengaged, and the aircraft began to shake. The Aircraft shook very severely, and the tense voices of the cabin attendants could be heard over the interphone.

The R Captain states that the weather radar had been on from prior to assuming the PIC's duties, but that no echoes had been displayed on the ND over Japan, including at the time when the accident occurred.

Approximately 10 seconds before the accident occurred, the Aircraft had entered light hazy cloud conditions, and at the time when the accident occurred, it became a little darker than before. It became clear after the accident.

The R Captain was notified by the purser that a few passengers were injured and that two of them were seriously injured. He was also notified that oxygen masks in the last row of the cabin had dropped, so he reported these matters to the OCC of the Company.

(3) FO

At the time when the accident occurred, the FO was resting in the cabin. At the beginning of the shaking, a cabin attendant returning a cart to the galley fell to the floor. As the cabin attendant was attempting to stand, the FO instructed the cabin attendant to remain in that position and hold on to a seat. The Aircraft had shaken severely for about three minutes.

The FO states that at the time of takeoff, the weather radar was on according to the pre-takeoff checklist, but does not remember whether it was turned off or remained on after that.

2.1.3 Statements of Cabin Attendants

(1) Purser

In the cabin briefing at Honolulu International Airport, the purser was informed by the PIC that turbulence was forecast approximately one hour before arrival at Incheon International Airport.

The purser was in the forward cabin when the accident occurred. In the economy class compartment, service had ended and all carts had been returned to the galley, the cabin attendants were cleaning up in the galley. Coffee service to the business class

compartment was being carried out, and the cabin attendants in charge of the mid cabin were assisting with the business class compartment service.

At the initial severe shaking, one of the carts whose brakes were locked began to slide, so the purser promptly held it down. According to the reports of the four cabin attendants who were pushing carts in the business class compartment, they were thrown into the air at this time. The purser was unable to make a PA due to holding down the cart; accordingly, the cabin attendant in charge of the mid cabin made a PA requesting passengers to fasten their seat belts. The second PA was made by the purser, and following it, the cabin attendants checked on whether the passengers had securely fastened their seat belts.

The Aircraft shook severely in all directions, causing equipment in the business class compartment to fall down and be broken.

Although the purser does not recall whether the Sign was illuminated before the severe shaking, the passengers and other cabin attendants who were asked this question replied that it had not been illuminated. There was a complaint from one passenger who was in the lavatory at the time when the accident occurred asking why the Aircraft shook suddenly even though the Sign was not illuminated.

(2) Cabin Attendant A

Cabin Attendant A was near the center of the rear cabin when the accident occurred.

Cabin Attendant A intended to make a PA to fasten seat belts when the Sign was on; therefore, Cabin Attendant A believed that the Sign had not been illuminated up until the severe shaking began. Since the Aircraft shook severely immediately after the Sign was turned on, Cabin Attendant A was thrown into the air and fell to the floor twice.

Cabin Attendant A observed Passenger A being thrown into the air and falling due to this shaking. During the shaking, the passenger in seat 40G helped Passenger A to stand, sit in the empty seat 38J, and then fasten the seat belt there. Later, when Cabin Attendant A moved closer to Passenger A to check on her condition, Passenger A stated that her leg was broken. Because Passenger A complained of severe pain when Cabin Attendant A placed an ice pack on the injured part, Cabin Attendant A believed that her leg was broken.

As a result of the continued severe shaking, more than half of the overhead bins in the economy class compartment opened. In particular, almost all of the overhead bins aft of row 36 were open with much luggage fallen on the floor.

2.1.4 Statements of Injured Passengers

(1) Passenger A

Returning to her seat from the lavatory, Passenger A was walking near seat 37J while holding on to the seats along the aisle. At the initial shaking, Passenger A was thrown into the air and fell forcefully to the floor. At this time, Passenger A lost her balance and injured her left ankle even though she was holding onto seats on both sides.

After this, since the Aircraft shook more severely three or more times, Passenger A was lying down on the floor and grabbing the bottom of 37G and 37F seats to cope with shaking.

(2) Passenger B

Passenger B was seated in seat 34G with her seat belt. In order to go and assist Passenger A, who was Passenger B's mother and had fallen down, Passenger B unbuckled

her seat belt. At that moment, the Aircraft shook again. Passenger B was thrown into the air and hit her occipital region on the ceiling, and when she fell down, she hit her face against the back of a front seat.

The severe shaking continued for about three minutes, causing the Aircraft to shake severely in all directions. The feeling was like that of a sharply descent when riding a roller coaster.

This accident occurred at around 15:17 on August 21, 2012, over Matsue City, Shimane Prefecture (35° 32' 07" N, 133° 09' 48" E), at an altitude of approximately 40,000 ft.

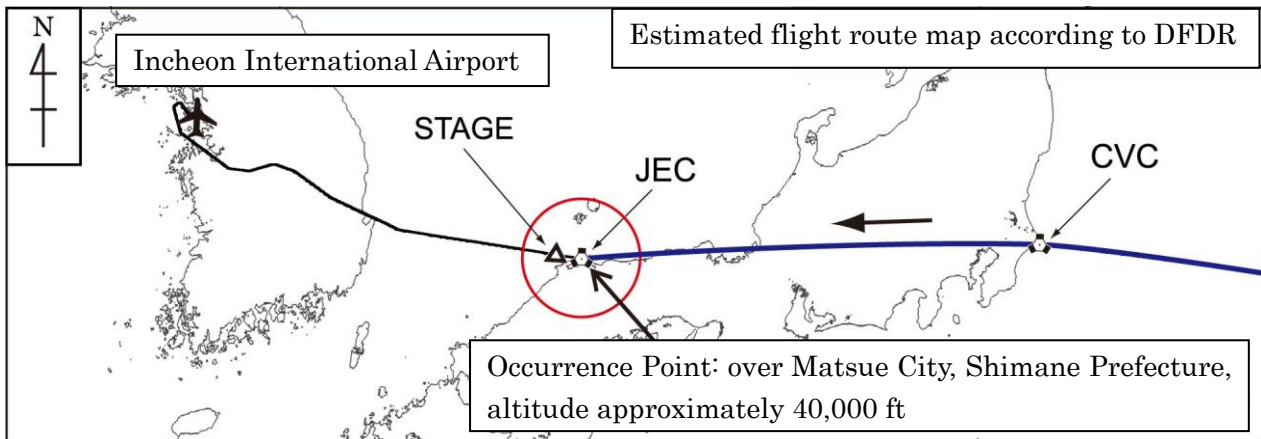

(See Figure 1: DFDR and CVR Records, Figure 2: Status of Changes in Wind Direction and Wind Speed Recorded by DFDR, Figure 3: Locations of the Injured Persons, and others at the time when the Accident Occurred, Attachment: Records of ATC Communications)

2.2 Damage to the Aircraft

After landing, the Aircraft underwent a special inspection which is required after encountering severe turbulence or exceeding M_{MO} ; however, no damage or anomalies were found.

2.3 The Dead, Missing, and Injuries to Persons

Two passengers (Passenger A and Passenger B) were seriously injured, while one passenger was slightly injured.

2.4 Personnel Information

(1) PIC Male, Age 57

Airline Transport Pilot Certificate (Airplane)

September 15, 2005

Type rating for Airbus A330

September 14, 2005

Class 1 Aviation Medical Certificate

Validity

November 30, 2012

Total flight time

20,068 hr 56 min

Flight time in the last 30 days

68 hr 15 min

Total flight time on the type of aircraft

5,045 hr 34 min

Flight time in the last 30 days

68 hr 15 min

(2) R Captain Male, Age 45

Airline Transport Pilot Certificate (Airplane)

January 31, 2011

Type rating for Airbus A330

January 31, 2011

Class 1 Aviation Medical Certificate	
Validity	October 31, 2012
Total flight time	5,549 hr 22 min
Flight time in the last 30 days	90 hr 35 min
Total flight time on the type of aircraft	2,433 hr 52 min
Flight time in the last 30 days	90 hr 35 min
(3) FO Male, Age 42	
Commercial Pilot Certificate (Airplane)	April 30, 2010
Type rating for Airbus A330	August 9, 2010
Instrument Flight Certificate	May 26, 2010
Class 1 Aviation Medical Certificate	
Validity	June 30, 2013
Total flight time	1,474 hr 43 min
Flight time in the last 30 days	78 hr 33 min
Total flight time on the type of aircraft	1,474 hr 43 min
Flight time in the last 30 days	78 hr 33 min

2.5 Aircraft Information

2.5.1 Aircraft

Type	Airbus A330-300
Serial number	1326
Date of manufacture	June 11, 2012
Certificate of airworthiness	AB12028
Validity	during which the Maintenance Manual has been effective
Category of airworthiness	Airplane, Transport T
Total flight time	1,054 hr 32 min
Time in service since the last regular inspection (A inspection on August 19, 2012)	44 hr 40 min

(See Figure 4: Three Angle View of Airbus A330-300, Photo: Accident Aircraft)

2.5.2 Weight and Balance

When the accident occurred, the Aircraft's weight and the position of the center of gravity are estimated to have been 352,560 lb and 29.12% MAC, respectively, within the allowable range (maximum landing weight of 412,264 lb and 14.0 to 41.0% MAC corresponding to the weight at the time when the accident occurred).

2.6 Meteorological Information

2.6.1 General Weather Conditions

According to the Asia Surface Analysis Chart, the Upper Air Analysis Chart (500hPa) and the Wind and Equivalent Potential Temperature Prognostic Chart (850hPa)*⁴ at 9:00 on the day of the accident, because there was a cold vortex*⁵ to the south of Shikoku and the low-level

*⁴ The "Wind and Equivalent Potential Temperature Prognostic Chart (850hPa)" is a prognostic chart indicating the extent of wind and warm, humid air currents around an altitude of 1,500 m.

*⁵ A "cold vortex" is an area of low pressure accompanying cold air in the upper sky.

moisture-laden warm air*⁶ moving around the edge of the high-pressure area over the sea to the east of Japan were flowing from the Pacific Ocean side into the West Japan region, the atmospheric conditions over all areas of West Japan became unstable making it easier for cumulonimbus to be generated.

According to the Upper Air Analysis Chart (200hPa) at 9:00 on the day of the accident and the Hourly Analysis Chart at 15:00 on the day of the accident, it is clear that the jet stream in the vicinity of Japan was moving from Northeast China to Russian Maritime Province; accordingly, the area in the vicinity of the accident airspace was a weak wind area separated far away from the jet stream, with low vertical shear values.

(See Figure 5: Asia Surface Analysis Chart, Figure 6: Upper Air Analysis Chart (500hPa), Figure 7: Wind and Equivalent Potential Temperature Prognostic Chart (850hPa), Figure 8: Upper Air Analysis Chart (200hPa), and Figure 9: Hourly Analysis Chart (vertical cross section))

2.6.2 Situation of Cumulonimbus

According to Rapid Scan Observation imagery *⁷, at 14:05, clouds with a low cloud top height were scattered in the vicinity of the accident airspace, but as time passed, more clouds developed, and at 15:15, immediately before the accident, clouds reaching a high-altitude cloud top height were analyzed.

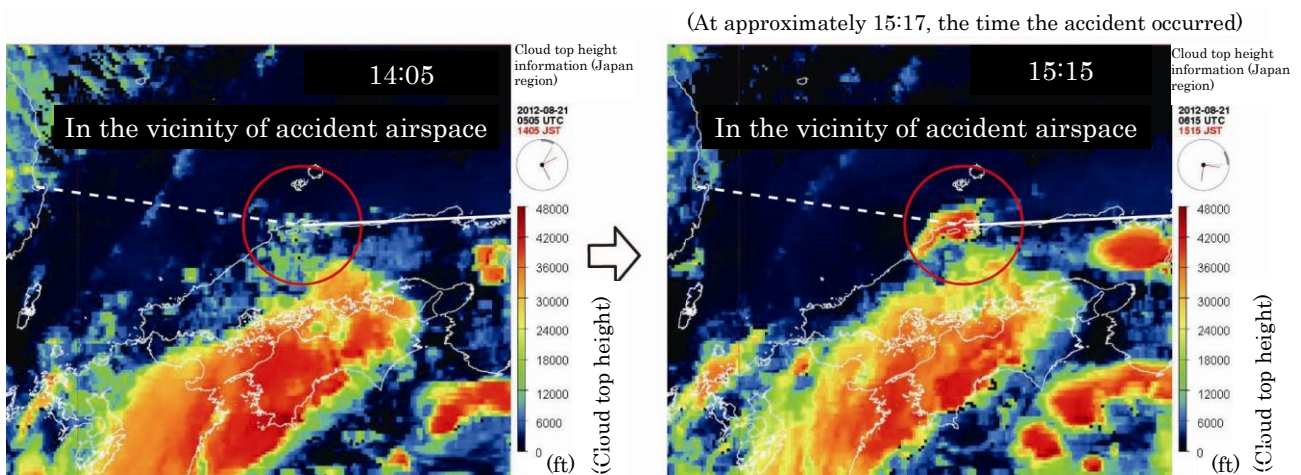

* Taken from and added to JMA's materials (JMA: Japan Meteorological Agency)

According to Doppler radar echo top distribution imagery from equipment installed at Miho Aerodrome adjacent to the accident occurrence point, within the time period of the accident multiple cumulonimbus were generated as a cluster in the vicinity of the accident airspace. The clouds were analyzed to be cumulonimbus with a cloud top height exceeding the Aircraft's flight altitude of 40,000 ft.

*⁶ "Low-level moisture-laden warm air" refers to the flow of warm, humid air currents located at lower levels.

*⁷ "Rapid Scan Observation Imagery" are satellite observation images taken at 5-minute intervals in the summer season (June to September), during which it is particularly easy for cumulonimbus to be generated. Standard satellite images are taken at intervals of approximately 30 minutes, and at times have not been able to accurately capture the conditions of cumulonimbus generation. Operation of these began in 2011.

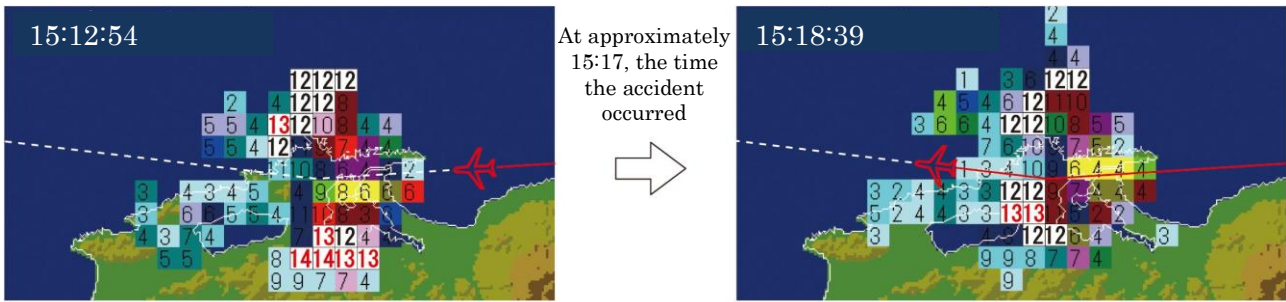

Numbers within frames indicate the maximum cloud top height (units: 1,000 m) within those frames.

	Maximum cloud top height within frame: 39,400 ft
	Maximum cloud top height within frame: 42,700 ft
	Maximum cloud top height within frame: 46,000 ft
	Estimated position of the Aircraft
* Taken from and added to materials provided by the Ministry of Defense	

2.6.3 Weather Briefing

According to the Significant Weather Prognostic Chart for International Aviation^{*8} issued by the London WAFC and confirmed by the PIC in the pre-flight briefing, the weather on the flight route after takeoff was favorable up until the accident occurrence point, and no significant weather conditions that would hinder the flight, such as cumulonimbus, were forecast; however, cumulonimbus with a cloud top height of 42,000 ft were forecast from the vicinity of Kinki and Shikoku to the area immediately south of where the accident occurred.

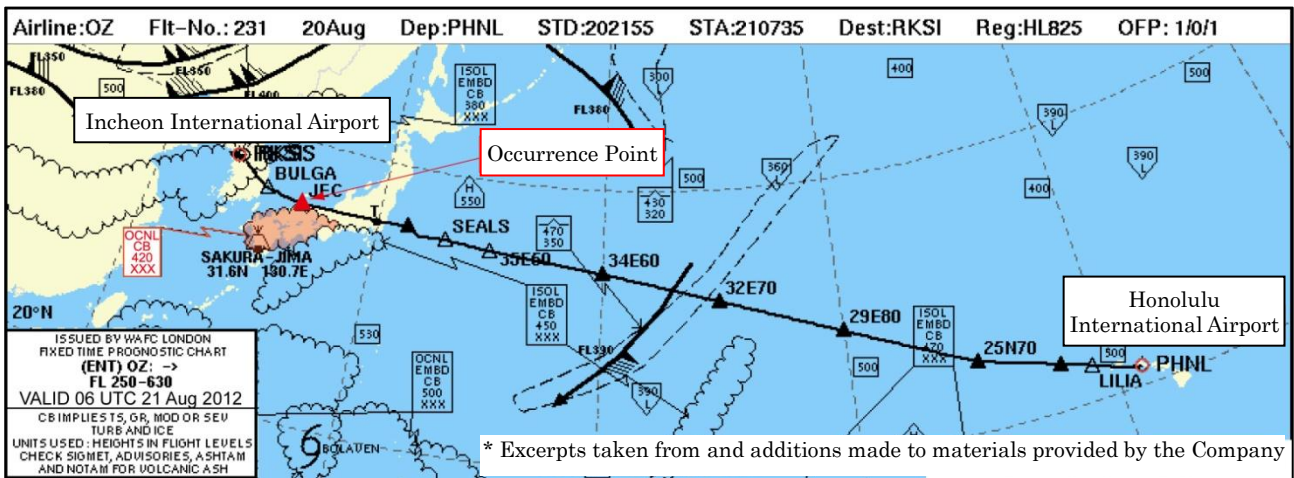

2.7 Information on DFDR and CVR

The Aircraft was equipped with a DFDR (part number: 2100-4045-00) and a CVR (part number: 2100-1026-02), both made by L-3 Communications of the United States of America.

All records at the time when the accident occurred were retained on the DFDR and the CVR. The time was determined by correlating the recorded VHF transmission keying signals during ATC communications retained in the DFDR with the JST time signals in the records of ATC communications.

^{*8} The “Significant Weather Prognostic Chart for International Aviation” describes the conditions of airspace at FL250 or higher, including significant weather phenomena (air turbulence, cumulonimbus, typhoons, volcanic eruptions) and jet streams.

2.8 Weather Radar

The weather radar detects precipitation droplets in the air and displays color-coded echoes on the ND according to the precipitation rates. By adjusting the tilt, gain, and range of the weather radar appropriately, flight crew is able to detect cumulonimbus and other significant weather from a long distance.

According to the DFDR records, while the Aircraft was ascending after takeoff from Honolulu International Airport, its weather radar was turned off at approximately 20,000 ft. After the accident occurred, when the altitude of the Aircraft had returned to approximately 40,000 ft and the shaking of the aircraft had subsided, it was turned on. In the CVR, however, there were no recorded conversations regarding the weather radar being turned on.

It was confirmed by inspections after landing that there were no malfunctions with the weather radar system.

If the weather radar is turned on and the weather radar image of each ND is turned on, the weather radar information will be displayed on each ND (excluding PLAN Mode). Therefore, if the weather radar image on the ND is turned on, the operating status of the weather radar can be confirmed by the display (e.g., radar sweep, tilt angle) on ND even if there are no echoes.

Example ND display

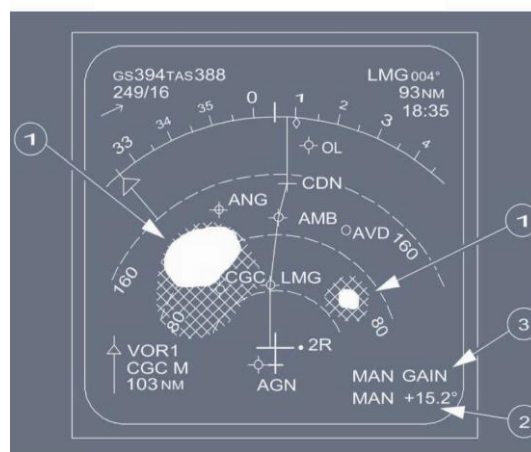

- ① Echo
- ② Tilt angle
- ③ Gain mode

2.9 Situation in the Cockpit until the Accident occurred

According to the CVR records, during the 30-minute period up until immediately before the accident occurred, the PIC and the R Captain had opened up the Company's regulations manuals and other materials to confirm the guidelines of operation and other matters assuming various phases. During this time, other aircraft were making communications with the Tokyo ACC to go around cumulonimbus, and terms including "CB" and "Deviation" were being used frequently. Nevertheless, there were no indications of particular attention being paid to these communications in the conversations between the PIC and the R Captain.

2.10 Other Information

2.10.1 Traffic Conditions around the Aircraft

According to the radar tracking records of Tokyo ACC, there were no other aircraft that would have been affected by the Aircraft's altitude deviation. The Aircraft was flying with applying RVSM*⁹, and it was obligatory to promptly notify the ATC if it encountered any turbulence that would affect the capability to maintain the cruising altitude.

2.10.2 The Company's regulation

- (1) The FOM of the Company includes the following description regarding notification in the event of turbulence.

*⁹ "RVSM" is an operation procedure that aircraft are vertically separated by 1,000ft, instead of the standard 2,000ft. It is applied mutually among all RVSM approved aircraft for altitudes between FL290 and FL410 in all areas of the Fukuoka FIR

(Excerpt)

2.8.3 Informing Turbulence

For clear and accurate communication between flight crew and cabin crew, terms for turbulence are categorized as Light, Moderate, Severe. When turbulence is expected or entering area of turbulence, the following procedure shall be observed.

- a. When turbulence is expected, captain must inform cabin crew before entering the area so that cabin crew can take precautionary action. (When, Where (altitude), Duration of expected turbulence and etc)*
- b. When captain switch on/off Seat Belt Selector, prior notice to cabin manager should be made.*
- c. When turbulence is expected or entering area of turbulence, captain must give Chime to cabin crews so that cabin crew can make necessary announcement. Captain may make an announcement if necessary.*
- d. If moderate/severe turbulence is encountered after captain switch on Seat Belt Selector, 2 chimes with Seat Belt Selector shall be made by captain. In this case, cabin crew must quickly make announcement and accomplish precautionary actions.*

(The rest is omitted)

- (2) The FCOM of the Company includes the following description regarding measures to be taken when severe turbulence is encountered.

(Excerpt)

PRO-SUP-91-10 SEVERE TURBULENCE

SIGNS

Before entering an area of known turbulence the flight crew and the cabin crew must secure all loose equipment and turn on the cabin SIGNS.

AUTOPILOT/AUTOTHURST

Keep the autopilot ON.

When thrust changes are excessive: Disconnect autothrust

(Omitted)

THRUST AND AIRSPEED

Set the thrust to give the recommended speed (Refer to PRO-SUP-91-10 Thrust Setting For Recommended Speed).

This thrust setting aims to obtain, in stabilized conditions, the speed for turbulence penetration given in the graph below.

Change thrust only in case of an extreme variation in airspeed, and do not chase your Mach or airspeed.

A transient increase is preferable to a loss of speed that decreases buffet margins and is difficult to recover.

(Omitted)

ALTITUDE

If the flight crew manually flies the aircraft:

- They can expect large variations in altitude, but should not chase altitude.

- They should maintain attitude, and allow altitude to vary.

(The rest is omitted)

(3) The FCOM of the Company includes the following description about exceeding VMO/MMO.

(Excerpt)

PRO-SUP-27-40 THE PROTECTION SYSTEMS

EXCEEDING VMO/MMO

(Omitted)

2. The current speed is close to the VMO (maximum operating speed) :

- *Monitor the speed trend symbol on the PFD :*
 - *If the speed trend reaches, or slightly exceeds, the VMO limit :*
 - *Use the FCU immediately to select a lower speed target.*
 - *If the speed trend significantly exceeds the VMO red band, without high speed protection activation :*
 - *Select a lower target speed on the FCU and, if the aircraft continues to accelerate, consider disconnecting the AP.*
 - *Before re-engaging the AP, smoothly establish a shallower pitch attitude.*

(The rest is omitted)

(4) The FOM of the Company includes the following description regarding use of the weather radar.

(Excerpt)

10.5.2.2 Airborne weather radar

a. Weather Radar general

(Omitted)

3) At least one or more airborne weather radar must be operating at night or in IMC condition. If all airborne weather radar is not available, captain (PIC) shall to the best his or her knowledge to select the safest possible route. (Recommended by Civil Aviation Safety Authority)

4) Weather radar shall be in the ON position before takeoff at night and in IMC condition.

b. Weather Radar technique

Use of weather radar, refer to FCOM and related manual.

- 1) Captain and co-pilot (F/O) shall select different range on ND for efficiently avoid thunderstorm using weather radar.*
- 2) Try to adjust weather radar antenna tilt to monitor echo and storm.*
- 3) Refer to FCOM/FCTM of your aircraft type for ideal method to avoid using weather radar.*

(5) The FOM of the Company includes the following description regarding entry into or flight in the vicinity of a thunderstorm.

(Excerpt)

10.5.2.5 Operation procedure

If you cannot avoid penetration a thunderstorm or fly near one, following are some techniques before entering the storm.

- a. Tighten your safety belt, put on your shoulder harness if you have one, and secure all loose objects.*
- b. Confirm seatbelt sign on, carts and galleys secured of loose items and passengers seated with seatbelts fastened. Remember turbulence felt at the tail is more*

intense than that of the cockpit.

- c. At least one of the flight crew members must focus on flying the aircraft. The other crew member shall monitor flight instruments.*
- d. Select your altitude so that you are clear of obstacles. It may not be easy to maintain safe flight path due to turbulence, sudden gust of wind or local altimeter setting.*
- e. Establish power settings for reduced turbulence penetration airspeed recommended in your aircraft manual.*
- f. Use autopilot as recommended in your aircraft manual. Autopilot reduces structural damage to the aircraft compare to manual flight. But disconnect auto thrust to minimize unnecessary change in airspeed.*

(The rest is omitted)

3. ANALYSIS

3.1 Qualification of Personnel

The PIC, the R Captain, and the FO all held valid airman competence certificates and valid aviation medical certificates.

3.2 Aircraft Airworthiness Certificates

The Aircraft had a valid airworthiness certificate and had been maintained and inspected as prescribed.

3.3 Relation to Meteorological Conditions

It is probable that the meteorological conditions in the vicinity of the accident airspace and their influence on the Aircraft during the time period of the accident were as follows.

3.3.1 Cumulonimbus

As described in 2.6.1, because there was a cold vortex to the south of Shikoku and the low-level moisture-laden warm air were flowing in from the Pacific Ocean side, the atmospheric conditions over all areas of West Japan became unstable, making it easier for cumulonimbus to be generated. In addition, as described in 2.6.2, cumulonimbus were generated rapidly in the vicinity of the accident airspace from approximately one hour before the accident occurred, with a cloud top height exceeding the Aircraft's flight altitude of 40,000 ft. Moreover, as described in 2.1.1 and 2.9, it was recorded in the CVR that immediately before the accident occurred, JEC was out of service due to a lightning strike and that other aircraft flying around the Aircraft had been communicating with the Tokyo ACC to avoid significant weather conditions.

Based on these facts, it is highly probable that cumulonimbus to which the PIC and the R Captain should pay attention existed in the vicinity of the accident airspace.

3.3.2 Clear-Air Turbulence

As described in 2.6.1, the accident occurrence point was an area of weak wind far away from the jet stream, with low vertical wind shear values. According to the statements in 2.1.2, the PIC indicated that at the time of the pre-flight weather briefing, the predictors of vertical shear in the Japan airspace were low. As described in 3.3.1, cumulonimbus existed in the vicinity of the accident airspace.

Based on these facts and statements, it is probable that there was no clear-air turbulence that would affect the operation of the Aircraft in the vicinity of the accident airspace.

3.4 History of the Accident

3.4.1 Atmospheric Disturbances

As described in 2.1.1, a relatively large change in vertical acceleration of the Aircraft started from the time the wind speed and direction began to change. The wind with a speed of 16 kt from the right rear changed over a short period of time to take on a direction opposing the Aircraft with a speed of 34 kt. It is highly probable that the Aircraft exceeded the M_{MO} due to the sudden increase of the headwind components by approximately 50 kt. At this time, it is highly probable that because the AOA increased rapidly but there was no change to the pitch angle, and because the SAT was

rising immediately after this, the Aircraft began to ascend, subjected to a strong updraft that lifted the entire aircraft. Subsequently, the largest value of vertical acceleration during the flight of 1.88G was recorded, which was immediately followed by a sudden shift of the wind in a counter-clockwise direction. When the wind changed to a crosswind, the vertical acceleration became 0.04G, recording the largest change during the flight.

According to the statements of 2.1.2, both the PIC and the R Captain indicated that approximately 10 seconds before the accident, the Aircraft had entered light hazy cloud conditions, and that at the time when the accident occurred it became a little darker than before. Additionally, judging from the conditions of the cumulonimbus described in 3.3.1, it is probable that the aircraft shook severely as a result of passing through or nearby cumulonimbus and encountering atmospheric disturbances with severe changes in wind direction and speed coupled with strong updrafts.

3.4.2 Disengagement of A/P

As described in 2.10.2(3), the regulations of the Company specify the procedures regarding exceeding VMO/MMO. According to the statements in 2.1.2, the PIC took over control from the R Captain, disengaging the A/P.

According to the statements in 2.1.2, the PIC disengaged the A/P and attempting to stabilize the Aircraft manually, but was not able to control it as desired. Moreover, as described in 2.1.1, when the PIC disengaged the A/P and pushed the sidestick forward, even though the changes in SAT and wind speed and direction just before pushing the sidestick forward were comparatively small compared to the conditions before the A/P was disengaged, the pitch angle of the aircraft decreased, and together with this the vertical acceleration reached the minimum value during this flight of -0.09G.

Based on these statements and records, it is possible that the severe shaking of the aircraft was occurred resulting from the PIC's operation after disengaging the A/P.

It is also probable that after this severe shaking of the aircraft, due to the large changes in wind speed and direction as well as SAT, the PIC experienced difficulties in stabilizing the Aircraft by manual control while at a high altitude and in the midst of atmospheric disturbances.

As described in 2.10.2(2), the regulations of the Company specify that the flight crew should keep the A/P on when encountering severe turbulence. As described in Figure 1 and in 2.1.2, since the changes in pitch angle after disengagement of the A/P showed significant fluctuations, it is possible that if A/P had not been disengaged, there may not have been such large changes in the pitch angle.

3.4.3 Occurrence of Injuries

According to the statements in 2.1.3 and 2.1.4(1), the initial shaking caused Passenger A to be thrown into the air and sustain serious injury when falling to the floor, a situation which was observed by Cabin Attendant A. Since the Aircraft was lifted and shaken as described in 3.4.1, it is probable that the serious injuries sustained by Passenger A occurred at the time of the change in vertical acceleration from 0.04G, recorded when the aircraft experienced shaking as a result of encountering severe atmospheric disturbances.

According to the statements in 2.1.4(2), when Passenger B removed their seat belt to help Passenger A, the Aircraft shook again causing Passenger B to be thrown into the air and fall.

Based on these statements, it may be that the injuries sustained by Passenger B occurred at

the time of the change in vertical acceleration following the disengagement of the A/P by the PIC.

3.5 Notification to Passengers and Measures Taken

3.5.1 Illumination of the Sign

According to the statements in 2.1.2, because there were light hazy clouds in the Japan airspace as well as some slight shaking, the PIC and the R Captain had turned the Sign on from some time earlier, and at the point where the Aircraft began to shake the Sign was turned on two times.

According to the statements in 2.1.3, however, the purser indicated that other cabin attendants and passengers had answered that the Sign was not illuminated before the aircraft began to shake severely, and that there was a complaint from one passenger asking why the Aircraft shook suddenly even though the Sign was not illuminated. Moreover, as described in 2.1.1, immediately before the relatively large change in vertical acceleration began, the operation sound of the Selector (one time) was recorded in the CVR.

Based on these statements and records, it is probable that because the Aircraft began to shake severely soon after the Sign was illuminated, the passengers were unable to take appropriate measures.

3.5.2 Cabin Attendants' Response to the Accident

According to the statements in 2.1.3, due to the sudden occurrence of severe shaking, the cabin attendants were holding down carts to prevent them from sliding or were thrown into the air from the shaking, and thus they were unable to make immediate PAs. As described in 2.1.1, the initial PA made by a cabin attendant was after the time of the largest change in vertical acceleration.

Based on these statements and records, it is probable that due to the sudden shaking of the aircraft, the cabin attendants were not able to provide passengers with prompt warning information.

3.6 Recognition of Cumulonimbus

According to the statements in 2.1.2, at the time when the accident occurred the PIC and the R Captain indicated that they were using the weather radar but that no echoes were displayed on the ND. As described in 2.1.1 and 2.8, however, the Aircraft's weather radar was off. Because there were no malfunctions found with the Aircraft's weather radar system, it is highly probable that if the weather radar image on the ND had been on, the operating status of the weather radar could have been confirmed even without echoes by using the ND display (e.g., radar sweep, tilt angle).

Besides, as described in 2.9, during the 30-minute period up until the accident, the PIC and the R Captain had opened up manuals and other materials to confirm the guidelines of operation and other matters assuming various phases. During this time, they should have been able to hear the reports transmitted by other aircraft regarding significant weather, but there were no indications of particular attention being paid to significant weather in the conversations between the PIC and the R Captain.

Based on these statements and records, it is probable that as the PIC and the R Captain were concentrating on their confirmation of operation guidelines, so their observation of the weather conditions and instruments was not sufficient, causing them to fail to realize that the weather radar was off and consequently preventing them from recognizing the existence of cumulonimbus.

According to the statements in 2.1.2, in the pre-flight weather briefing, it was forecast that although there would be clouds with a cloud top height of 42,000 ft around the flight route, there would be no significant weather conditions such as clouds forecast on the flight route itself, including the accident point. Due to the possibility of surrounding clouds expanding to the accident point, however, it was necessary for the Captain and the R Captain to continually obtain the most current weather information from the OCC and other organizations during flight and also to pay close attention to the weather conditions on the flight route by watching outside and using the weather radar.

As described in 2.8, although it is recorded that the weather radar was turned off while the Aircraft was ascending after takeoff from Honolulu International Airport and turned on after the accident occurred when the shaking of the aircraft had subsided, there were no conversations recorded in the CVR regarding the weather radar being turned on. Since the responsibilities for operation of the Aircraft were assumed by the three flight crew in turn, it is probable that the mutual understanding among the flight crew and their communication at the time of changeover was insufficient.

3.7 Reports to ATC

As described in 2.1.1 and 2.10.1, due to the Aircraft's deviation from the assigned altitude, the PIC was obligated to promptly notify the ATC, but notification to the Tokyo ACC was made after the Aircraft had returned to its assigned altitude. As described in 2.1.1 and 2.1.2, it is probable that the notification to the Tokyo ACC was delayed because the PIC and the R Captain were using all of their ability to address the Aircraft's altitude deviation and the shaking of the aircraft. As described in 2.10.1, there were no other aircraft flying near the Aircraft when the accident occurred, and it is highly probable that as a result, the Aircraft's altitude deviation did not lead to any conditions causing hindrances to air traffic control. However, as the flight was being conducted under RVSM, the R Captain who had the duty as the PM was required to promptly notify the Tokyo ACC.

Moreover, as described in 2.1.1, at the time of the notification of turbulence to the Tokyo ACC, the PIC did not use standard terminology but used the term "Big Turbulence" instead; therefore, it is highly probable that the Tokyo ACC was unable to recognize the notification as one regarding turbulence and consequently did not go so far as to give this information to following aircraft. The pilot report on significant weather encountered by an aircraft is a useful information source that can contribute to the safety of subsequent aircraft flying in the reported area by allowing the pilots to select a safe altitude and route. The PIC was required to follow the ICAO standard and use the terminology "Severe Turbulence" when making the notification to the Tokyo ACC.

4. PROBABLE CAUSES

It is highly probable that in this accident, serious injury was sustained by a passenger walking in the rear aisle due to the severe shaking of the Aircraft, and that serious injury was sustained by another passenger seated nearby when the passenger removed the seat belt in order to help the injured passenger, the Aircraft shook severely again at that moment.

It is probable that the initial severe shaking of the Aircraft was a result of the Aircraft passing through or nearby cumulonimbus, due to the PIC and the R Captain failing to notice that the weather radar was off, and encountering atmospheric disturbances with severe changes in wind direction and speed coupled with strong updrafts. It is possible that the next shaking of the Aircraft may have been influenced by the PIC's control operations after disengaging the A/P to stabilize the aircraft.

It is probable that the reason for the PIC and the R Captain failing to notice that the weather radar was off was that their monitoring of the weather conditions and instruments was insufficient.

5. ACTIONS TAKEN

5.1 Safety Actions Taken

5.1.1 Action Taken by the Company

In response to the occurrence of this accident, the Company has taken the following measures, in addition to verification of the accident through ground training:

- (1) On August 21, 2012, the Company notified its flight crew members of this case along with the following items as points for enhancement of safety.
 - We strongly recommend to brief turbulence information during a joint briefing and perform the safety procedures.
 - Try to get real time weather through the information of ATC turbulence, weather radar and your eyes.
 - Perform the severe turbulence procedures with cabin crew when severe turbulence is expected or encountered.
 - Captain should make PA to relieve anxiety of passengers due to turbulence.
 - Make and maintain GOOD CRM.
- (2) On August 24, 2012, the Company notified its cabin attendants of this case along with the following items as points for enhancement of safety.
 - When the seat belt sign is on, continuously monitor that passengers are fastening their seatbelts no matter how serious the turbulence is.
 - Cabin crew make an immediate cabin announcement to provide passengers with instructions for appropriate action in the case of turbulence even the other announcement is being already made.
 - Ensure the policy and associated procedures regarding turbulence level. Please refer to CCM 2.10.
 - When the seat belt sign is on, senior cabin crew contacts captain to check the time of configuration of the turbulence.
 - Recently the number of unexpected turbulence has increased due to unstable air. Please always secure cabin.
- (3) In response to the improvement recommendation (Enhance PAs for fastening of seat belts during flight. Carry out education to prevent reoccurrences.) from MLTM (Ministry of Land, Transport and Maritime Affairs, the Republic of Korea), on September 21, 2012, the Company notified its flight crew and cabin attendants of the following internal safety recommendations to protect passengers from unexpected clear-air turbulence.
 - Captain should stress the importance of taking passengers' seatbelt full-time in flight during his/her joint briefing with cabin crew.
 - If turbulence is expected by weather forecast, notify cabin crew member and passengers should return to their seats with seatbelts fastened.
 - Captain(PIC) shall use PA and seatbelt sign to ensure seatbelts are securely fasten.
 - If possible, Captain make PA to free passengers from fear in a condition that ensure flight safety in case of unexpected turbulence.

5.1.2 Action Taken by the design and manufacture company of the Aircraft

The design and manufacture company of the Aircraft deleted the procedures of EXCEEDING

VMO/MMO in FCOM from PRO-SUP-27-40 THE PROTECTION SYSTEMS on February 15, 2013, and inserted it into PRO-ABN-10 OPERATING TECHNIQUES as OVERSPEED RECOVERY.

(Excerpt)

PRO-ABN-10 OPERATING TECHNIQUES

OVERSPEED RECOVERY

As soon as the speed exceeds VMO/MMO, apply the following actions:

AP : KEEP ON

SPEED BRAKES LEVER..... FULL

THRUST REDUCTION.....MONITOR

- *If the A/THR is OFF:*

ALL THR LEVERS.....IDLE

- *If the AP automatically disengages:*

HIGH SPEED PROTECTION : ACTIVE IN NORM LAW

The activation of the high speed protection results in an automatic pitch up in order to reduce the speed.

- *While the speed is above VMO/MMO:*

SPEED BRAKES LEVER : KEEP FULL

PITCH ATT.....ADJUST SMOOTHLY AS RQRD

(The rest is omitted)

Figure 1: DFDR and CVR Records

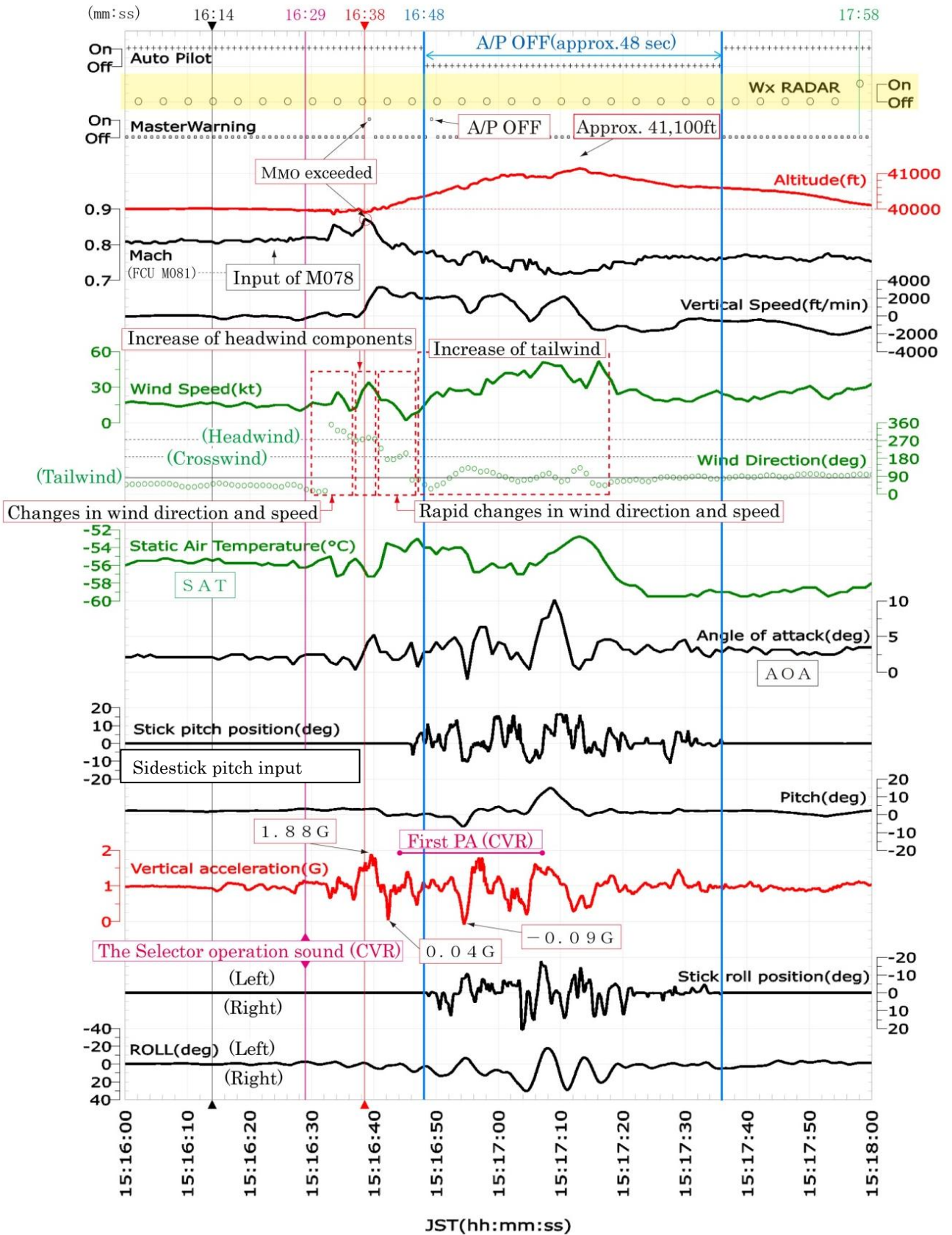
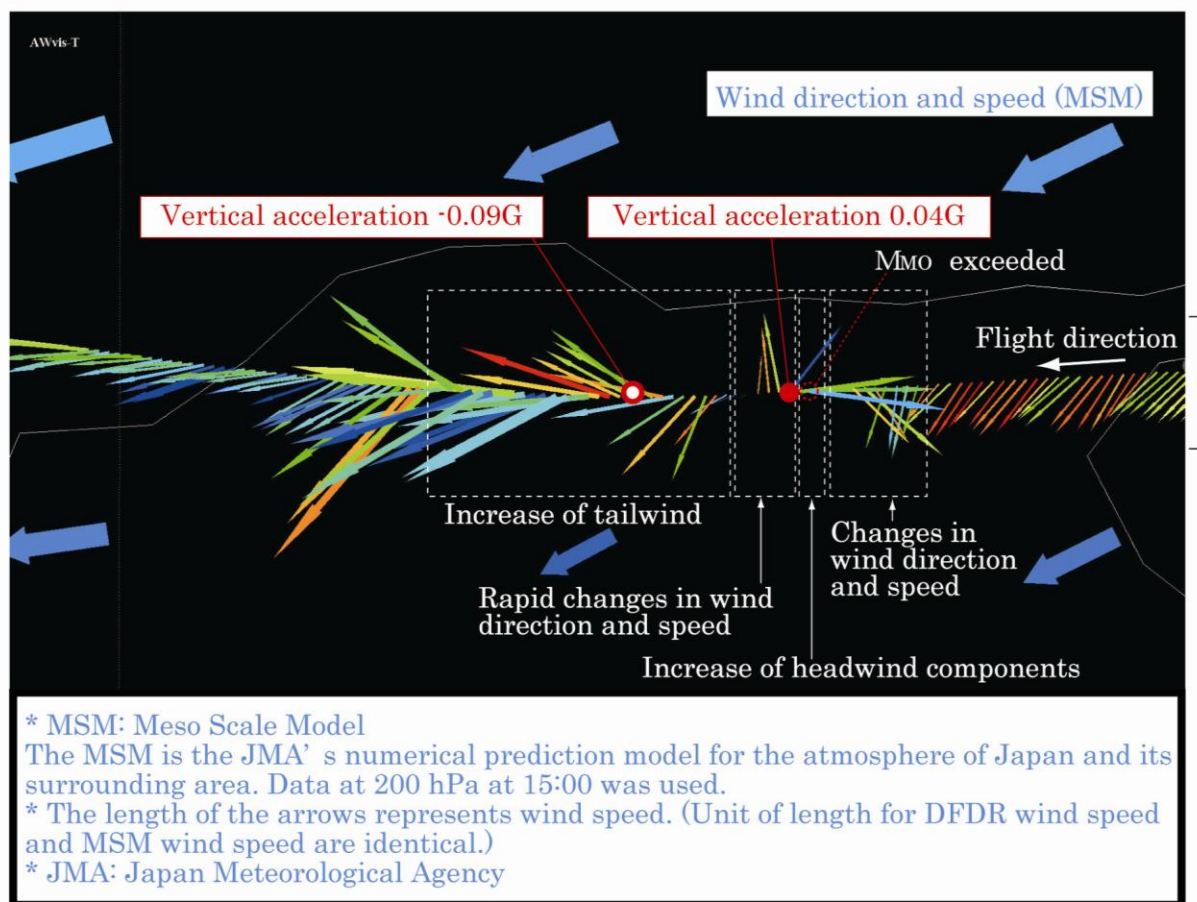

Figure 2: Status of Changes in Wind Direction and Wind Speed Recorded in DFDR



Wind direction and speed (DFDR)

* Added to Electronic Navigation Research Institute materials
 Uses Awvis (Aviation Weather Data Visualization Tool)

Figure 3: Locations of Injured Persons and others At the Time when the Accident Occurred

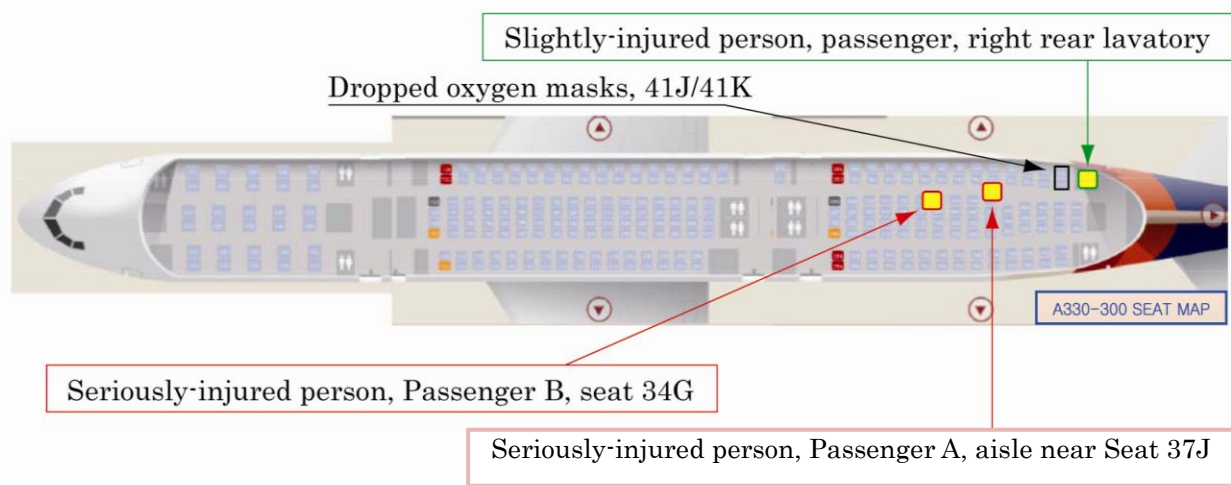

Figure 4: Three Angle View of Airbus A330-300

Unit: m

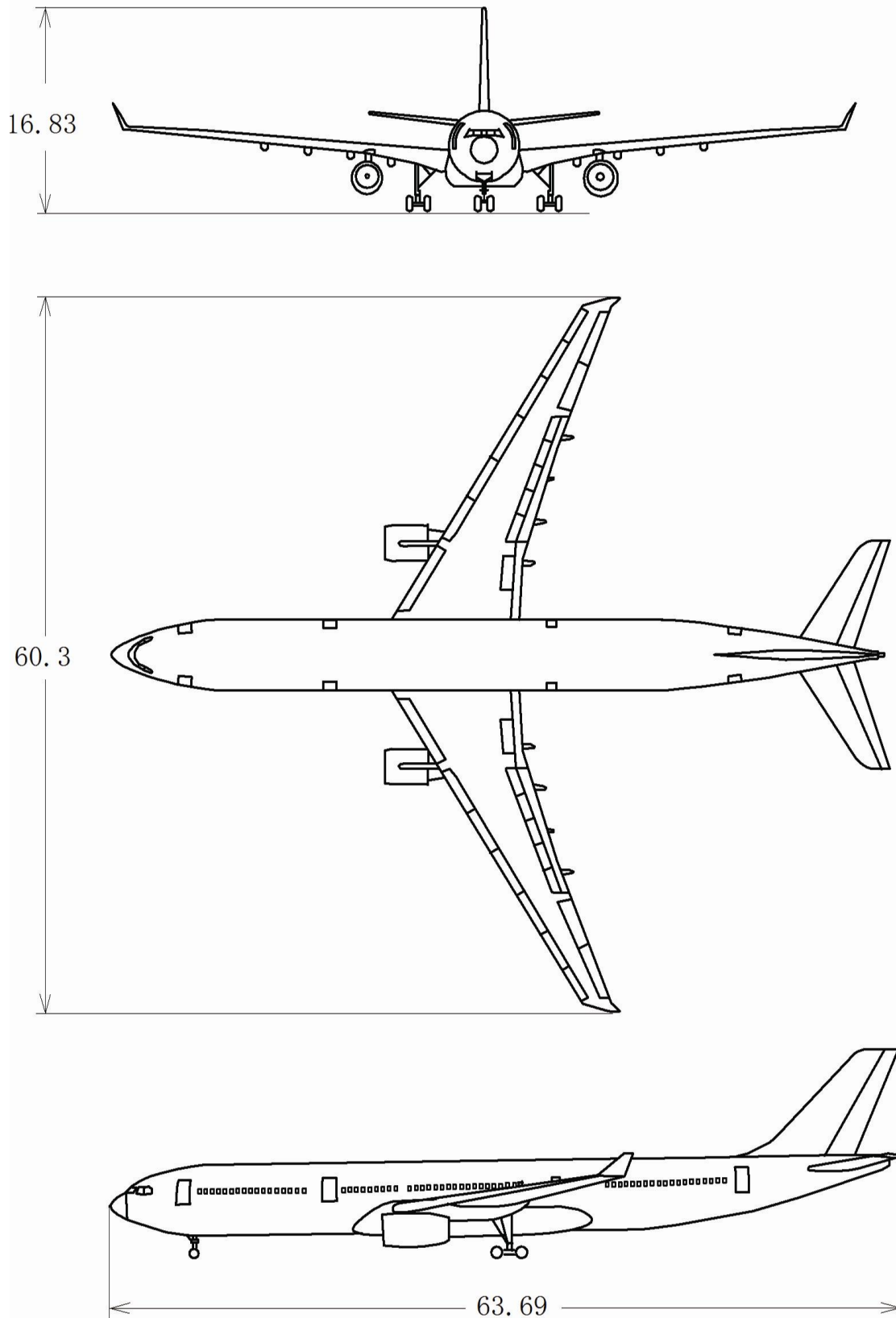

Figure 5: Asia Surface Analysis Chart

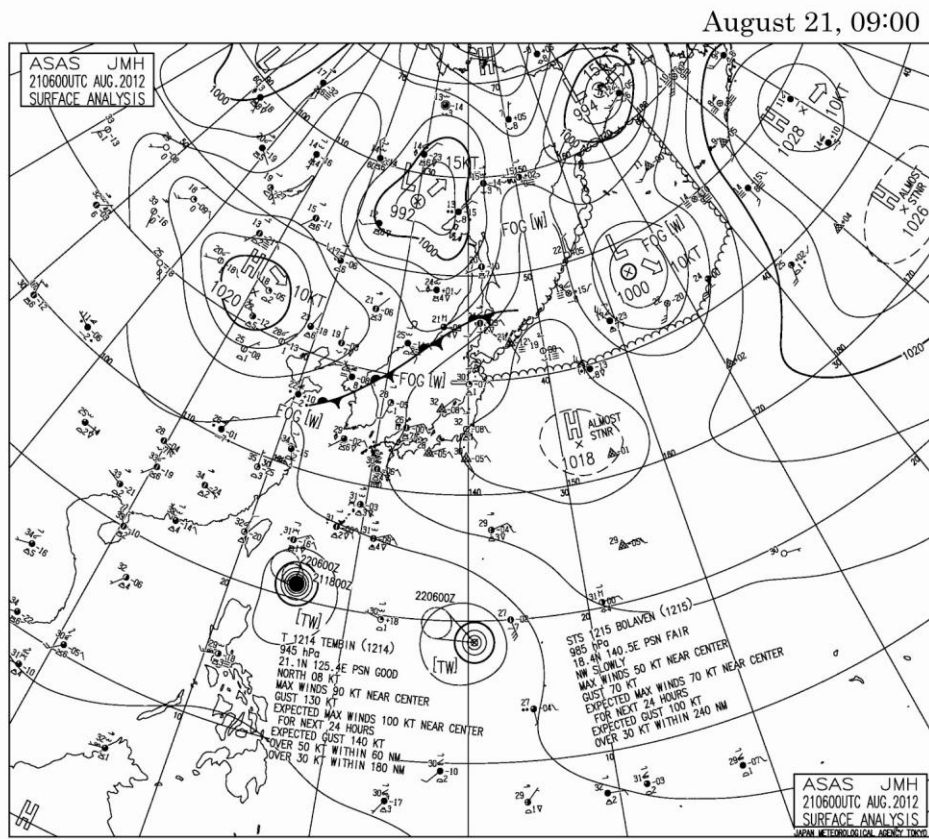
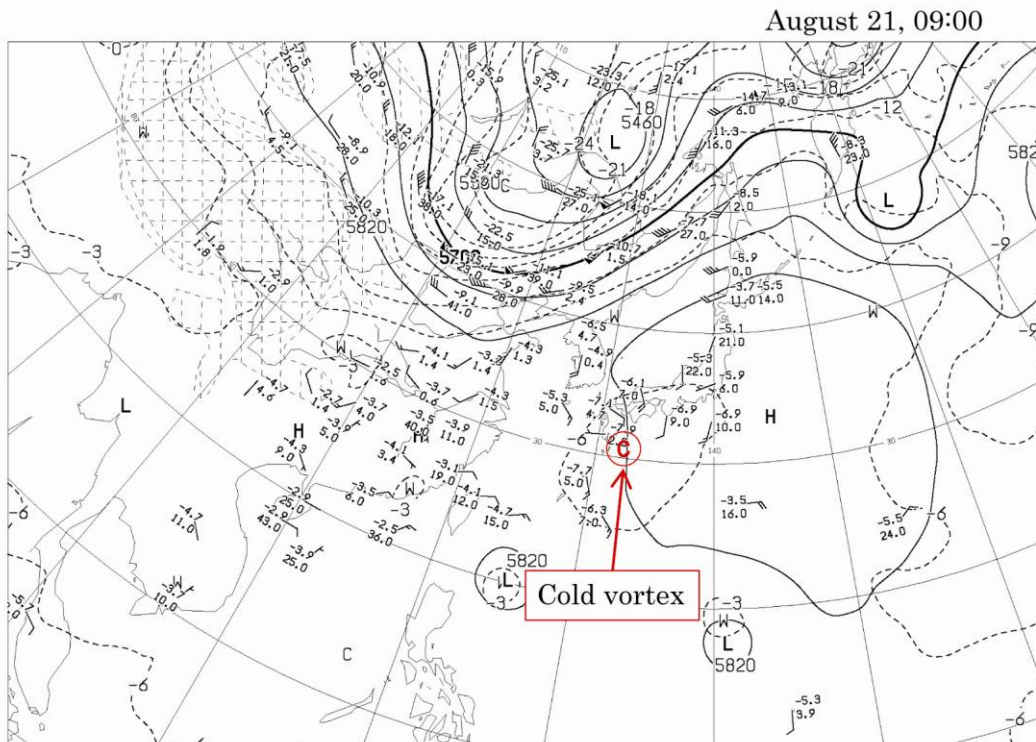

Figure 6: Upper Air Analysis Chart (500hPa)





AUPQ35 210000UTC AUG 2012

Japan Meteorological Agency
* Added to JMA materials

Figure 7: Wind and Equivalent Potential Temperature Prognostic Chart (850 hPa)

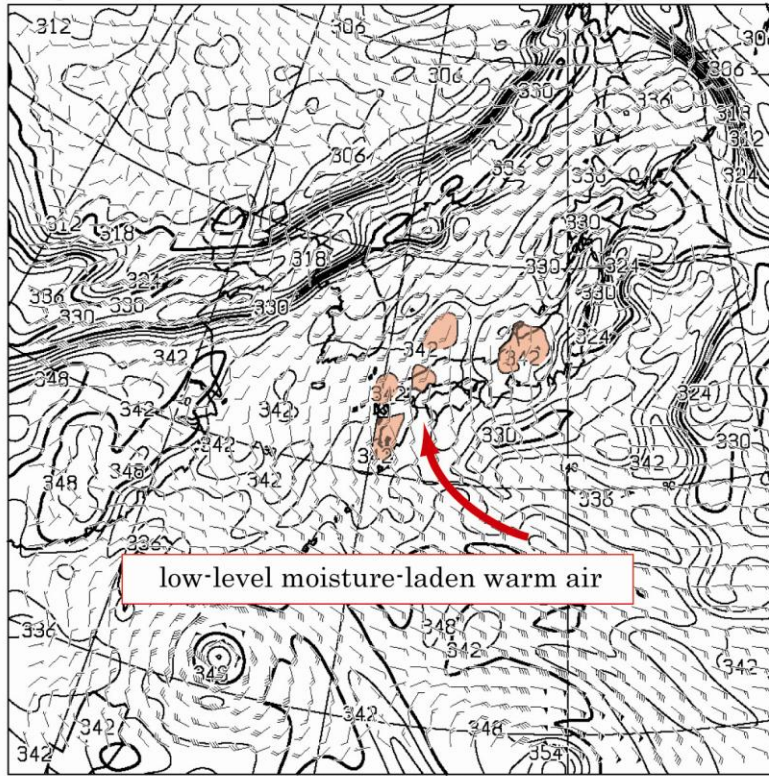
Prognostic chart for 12 hours after 09:00 on August 21



 : Region of equivalent potential temperature 342K or higher (K: Kelvin)

* The value of equivalent potential temperature increases with higher temperature or humidity.

T=12 850hPa: E.P. TEMP(K), WIND(KNOTS) VALID 211200UTC

* Added to JMA materials

Figure 8: Upper Air Analysis Chart (200hPa)

August 21, 09:00

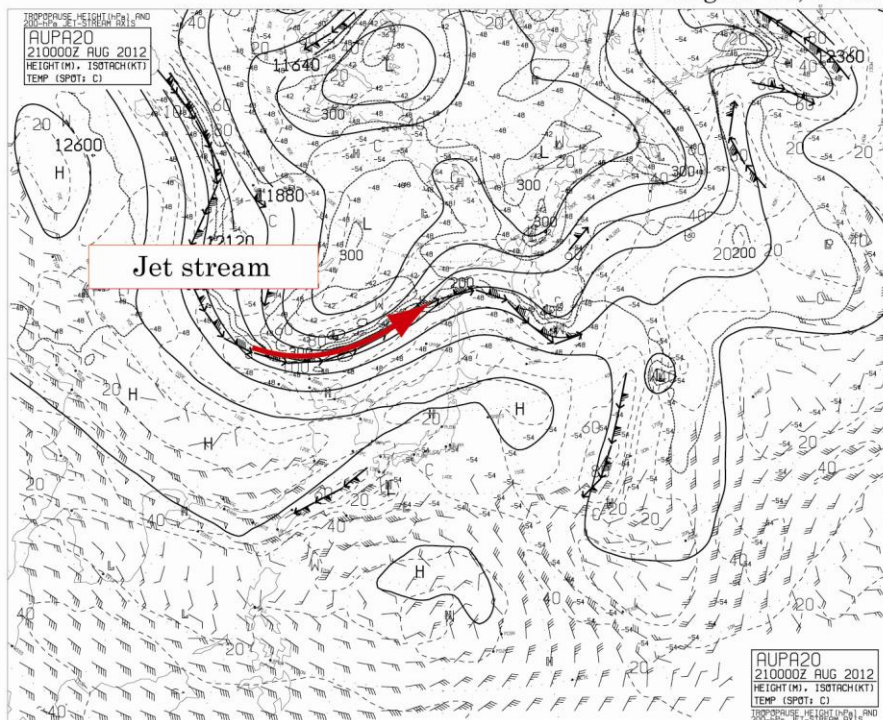
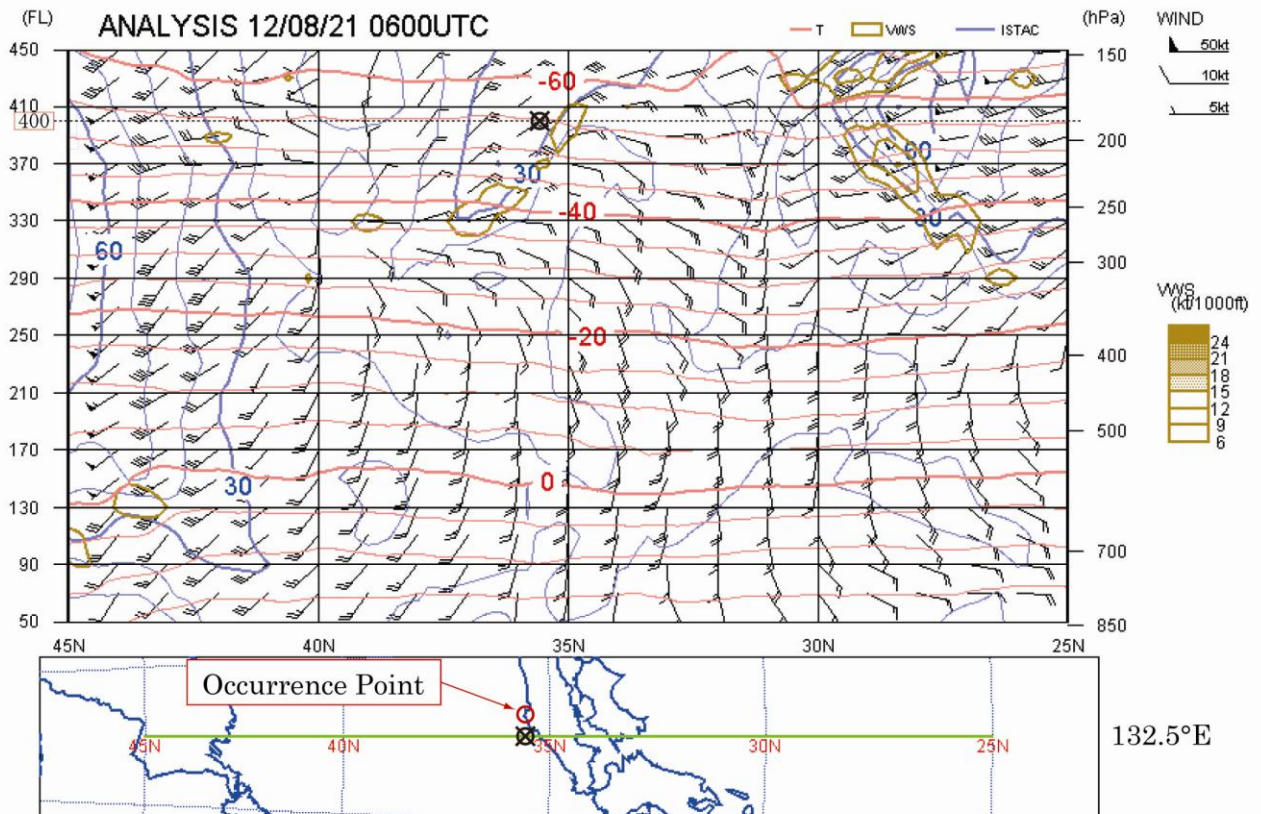

Figure 9: Hourly Analysis Chart (vertical cross section)

132.5°E 15:00 on August21



* Added to JMA materials

Photo: Accident Aircraft



Attachment: Records of ATC Communications

JST hh:mm:ss	Origin	Contents
15:10:25	AAR231	Tokyo Control, AAR231, maintain FL400.
	ACC	AAR231, Tokyo Control, roger.
15:18:17	AAR231	Tokyo, AAR231.
15:18:22	AAR231	Tokyo Control, AAR231.
	ACC	AAR231, go ahead.
15:18:26	AAR231	We hit big turbulence enroute on this position and altitude difference over 1,000 plus minus.
	ACC	AAR231, roger.
15:18:40	AAR231	And, we are now back to level 400.
	ACC	Ah, confirm you, you can keep maintain FL400?
15:18:49	AAR231	Affirmative, we are level 400.
	ACC	Roger.
15:30:23	ACC	AAR231, contact Incheon Control 120.57.
	AAR231	Confirm AAR231, 12057?
	ACC	Affirm, AAR231, contact Incheon 120.57.
	AAR231	OK, AAR231, 12057 good day.
	ACC	Good day.

AAR231: Asiana231 ACC: Tokyo ACC